



*Technique de pesage*



D800 Terminal



Use and maintenance manual



## Index

1. GENERAL	1-7
1.1 Declaration of conformity	1-7
1.2 Foreword	1-8
1.3 Symbols	1-10
1.4 Documentation	1-11
1.5 Description of the terminal	1-11
1.6 Technical characteristics of the terminal	1-12
1.7 Dimensions and weight of the terminal	1-13
1.8 Obtaining technical assistance	1-14
1.9 Replacement parts list	1-16
1.10 Warranty	1-17
2. SAFETY INSTRUCTIONS	1-19
2.1 Prohibited uses	1-19
2.2 Regulations	1-19
2.3 Prescriptions of use	1-19
3. DELIVERY AND INSTALLATION	1-21
3.1 Connection of the terminal to the electrical supply line	1-23
3.2 Connection of the terminal to the platform scale	1-24
3.2.1 Equipotentiality between the terminal and the platform scale	1-25
3.2.2 Connection of analogue load cells	1-25
3.2.3 Connection of digital load cells	1-26
3.3 COM1 serial port connection	1-27
3.4 COM2 serial port connection	1-28
3.4.1 Connection of COM2 in RS232 configuration	1-28
3.4.2 Connection of COM2 in RS422 configuration	1-29
3.4.3 Connection of COM2 in RS485 configuration	1-30
3.5 COM3 serial port connection	1-31
3.6 External keypad connection	1-31
3.7 Printer connection	1-32
3.8 Input/Output connection	1-32
4. CONTROLS, DISPLAY, SWITCHING THE TERMINAL ON AND OFF	1-35
4.1 Display of weight and additional information	1-35
4.1.1 Selection display symbols	1-37
4.2 Weighing function keys	1-38
4.3 Operating keys	1-40
4.4 Editing keys	1-40
4.5 Numeric keyboard	1-41
4.6 Alphabetical keyboard	1-42
4.7 External keyboard (optional)	1-42
4.8 Switching the terminal on and off	1-44
5. USE OF THE TERMINAL	1-47
5.1 General	1-47
5.1.1 Using the keys to browse the menus	1-47
5.1.2 Access to the functions	1-47
5.1.3 Special characters	1-48
5.1.4 Shortcut keys	1-49
5.1.5 Operating modes	1-49

5.2	User menu	1-50
5.2.1	User Menu tree for single weighing mode operation	1-50
5.2.2	User Menu Tree for double weighing mode operation	1-51
5.2.3	Complete User Menu Tree	1-54
5.3	List of terminal functions	1-57
5.3.1	Single weighing functions: standard	1-58
5.3.2	Single weighing functions: weight sum mode	1-58
5.3.3	Single weighing functions: extraction	1-59
5.3.4	Double weighing functions: RCD + RPD	1-59
5.3.5	Double weighing functions: RCD Plate + RPD	1-60
5.3.6	Double weighing functions: RCD + RPD Plate	1-60
5.3.7	Double weighing functions: RCD Plate + RPD Plate	1-61
5.3.8	Double weighing functions: without RCD or RPD with manual entry of first weight	1-61
5.3.9	Double weighing functions: only RCD or RCD Plate	1-62
5.3.10	Double weighing functions: RPD or RPD Plate	1-62
5.4	Description of the functions	1-63
5.4.1	Lists: use	1-63
5.4.2	Lists: code recall	1-63
5.4.3	Lists: item insertion	1-64
5.4.4	Lists: print-out	1-65
5.4.5	Lists: code deletion	1-65
5.4.6	Scale selection (available in terminals with more than one scale)	1-66
5.4.7	Adjusting the contrast	1-66
5.4.8	Lighting	1-66
5.4.9	Changing the date and time	1-67
5.4.10	Weight display (only available in single weighing mode)	1-67
5.4.11	Memory status	1-70
5.4.12	Reprint	1-70
5.4.13	Diagnostics A - Diagnostics B (only for terminals connected to digital load cells)	1-70
5.4.14	Setting the outputs as Set-points (if enabled)	1-71
5.4.15	Setting the outputs as Ranges (if enabled)	1-71
5.4.16	Product code	1-71
5.4.17	Client code	1-72
5.4.18	Generic code (only available in single weighing mode)	1-72
5.4.19	Plate (only available in double weighing mode)	1-72
5.4.20	Coefficient code	1-73
5.4.21	Data recall (only available in double weighing mode)	1-73
5.4.22	Plate recall (only available in double weighing mode)	1-73
5.4.23	Preset plate recall (only available in double weighing mode)	1-74
5.4.24	Preset weight recall (only available in double weighing mode)	1-74
5.4.25	TCA codes (only available in single weighing mode)	1-74
5.4.26	Display range (only available in single weighing mode)	1-75
5.4.27	Preset tares (only available in the single weighing mode)	1-75
5.4.28	Progressive number	1-76
5.4.29	Modifiable archives	1-77
5.4.30	Totals management	1-77
5.4.31	Display MPP data item	1-81
5.4.32	MPP operation	1-81
5.4.33	Customizable fields	1-81

---

5.4.34	Cut paper function	1-81
5.4.35	Timed high resolution mode	1-81
5.5	Printing weighing data	1-82
5.5.1	Weighing data reprint	1-82
6.	SINGLE WEIGHING MODE	1-83
6.1	Standard operation	1-83
6.2	Sum weighing operation	1-84
6.3	Loading extraction operation	1-84
6.4	Unloading extraction operation	1-85
7.	DOUBLE WEIGHING MODE	1-87
7.1	Entry-Exit functions	1-88
7.1.1	Entry operations in Entry/exit mode with Data recall	1-88
7.1.2	Exit operations in entry/exit mode with Data Recall	1-90
7.1.3	Unused RCD code recovery	1-92
7.1.4	Entry/Exit operations with Licence Plate Data Recall	1-93
7.2	Preset weight options	1-95
7.2.1	How to make the list of preset weights	1-95
7.2.2	Weighing procedures with preset weights	1-96
7.3	Options for entering the first weight manually	1-97
8.	OPTIONS	1-99
8.1	4 I/O board	1-103
8.2	Board with 4in/12out	1-104
8.3	BCD parallel 5V	1-106
8.4	Calculator BCD	1-108
8.5	Parallel 24V source current BCD (positive common)	1-110
8.6	Serial port expansion board	1-113
8.6.1	Jumper RS485 - COMx2	1-115
8.7	MPP memory expansion boards	1-116
8.7.1	Memory capacity	1-116
8.7.2	Operation	1-116
8.7.3	Disabling MPP	1-117
8.7.4	Checking memorised weight data	1-118
8.8	12-24Vac-dc input power supplier	1-119
8.9	Printers	1-121
8.10	Connection of terminals in a network	1-122
9.	MAINTENANCE	1-123
9.1	Battery	1-123
9.2	Changing the fuses	1-123
10.	TROUBLESHOOTING	1-125
10.1	Malfunctions	1-125
10.2	Error messages	1-126



## 1. GENERAL

### 1.1 Declaration of conformity

See QUICK START manual.

## 1.2 Foreword

- ✓ The aim of this manual is to provide the operator, through the use of text and illustrations, with essential information regarding the installation, safe operation and maintenance of the weighing system.
- ✓ This manual must be kept in a safe place where it is readily available for consultation. Always observe the instructions contained in the manual!
- ✓ The safe operation of the system is the responsibility of the operator, who must have a thorough knowledge of the system.
- ✓ The user is responsible for ensuring that the installation conforms to the applicable regulations.
- ✓ The equipment must be installed by specialised personnel who have read and understood this manual.
- ✓ "Specialised personnel" means any personnel who, by virtue of the training they have received and their professional experience, have been explicitly authorised by the "System safety supervisor" to install, operate and maintain the system.
- ✓ In the event of any problems, contact your nearest Service Centre.
- ✓ Any attempt on the part of unauthorised personnel to dismantle or modify the terminal is prohibited; any such attempt shall invalidate the warranty and release the manufacturer from all liability for any injury or damage.
- ✓ The alteration or removal of the data plates and seals is strictly prohibited; check that all plates and seals are present and legible, if not contact After-Sales Service.
- ✓ The manufacturer shall not be liable for any damages caused by incorrect handling of the terminal.
- ✓ The information and illustrations contained in this manual were up to date at the time of publication.
- ✓ The Manufacturer is committed to a policy of continuous product improvement and system components may therefore be subject to modification.
- ✓ All the technical information contained in this manual remains the exclusive property of the manufacturer and may not be divulged to third parties.
- ✓ No part of this document maybe reproduced or transmitted in any

form, including publication in computerised form or on the World Wide Web, without the express written permission of the manufacturer.

- ✓ This manual may not be used for purposes other than those directly related to the installation, operation and maintenance of the terminal.
- ✓ In order to more clearly illustrate certain maintenance or adjustment operations, some of the illustrations in this manual show the weighing system with the safety guards removed. Under no circumstances may the system be operated in these conditions. Do not operate the system in these conditions under any circumstances whatsoever, but remove the safety guards for the time strictly required to carry out the required repairs or maintenance then fit them back in place.

### 1.3 Symbols

Below is a list of the symbols used in this manual to alert the reader to the various hazards associated with the operation and maintenance of the instrument.

---

 **DANGER** 

---

Denotes an operation or procedure where failure to observe the instructions will result in death or serious injury.

---

---

 **CAUTION** 

---

Denotes an operation or procedure where failure to observe the instructions could result in minor injury or damage to the instrument.

---

---

 **WARNING** 

---

Information or instructions on how the system is to be operated correctly in order to maximise its service life or prevent loss or damage of programmed data or to optimise operation with regard to metrological standards.

---

Text and messages displayed on the terminal are printed in this manual using special characters.

#### Messages:

Display messages appear like this.

#### Menu pathways:

2°F>MENU>Contrast.

The character > indicates the transition from one menu option to the next.

## 1.4 Documentation

This manual is accompanied by a CD-ROM that primarily contains information about the installation of the terminal.

Here you will find information on how to interface the terminal with a PC and PLC.

## 1.5 Description of the terminal

The digital weight indicator allows highly accurate and reliable weighing. It is mainly designed to weigh vehicles and for commercial weighing purposes. The graphic display and fully alphanumeric keypad make it ideal for use by even inexperienced operators.

Some of the main features of the indicator are listed below:

- ✓ facility for connection to a maximum of 2 scales with analogue load cells (up to 24 x 350 ohm load cells)
- ✓ facility for connection to a maximum of 2 scales with digital load cells (up to 16 CPD load cells)
- ✓ three RS232/422/485 serial ports
- ✓ 2 inputs and 2 relay outputs
- ✓ 110/240 Vac power
- ✓ can be connected to the keyboard of a compatible external PC

Optional boards to interface the indicator and expand the system can be added on request.

## 1.6 Technical characteristics of the terminal

Power supply:	85-265 Vac 50/60 Hz
	12-24 Vdc (optional)
Maximum power:	50 W
Load cell connection:	up to 12 x 350 ohm analogue load cells via 9-pin connector per scale input
	up to 12 x CPD digital load cells via 15-pin connector for 1 scale input (up to 8 load cells per input in the event of a duplex)
Minimum impedance:	29 ohm (per analogue input)
Analogue load cell power:	10 Vdc
Digital load cell power:	10 - 18 Vdc
Internal resolution:	500000 points @ 25 conv/sec
	120000 points @ 100 conv/sec
Resolution in type-approved version:	10000 divisions maximum
Maximum input signal:	23 mV
Sensitivity:	0.75 uV/division (version with analogue load cells)
Full scale stability:	< 5 ppm/°C
Zero stability:	< 5 ppm/°C
Compensated temperature range:	-10 + 40 °C
Operating temperature range:	-10 + 50 °C
Protection class:	IP20
Humidity:	85 % at 40°C

Output contacts:	mechanical contact
Switchable voltage:	110 Vac/dc maximum
Switchable current:	200 mA maximum
Keypad input	PS2 compatible

### 1.7 Dimensions and weight of the terminal

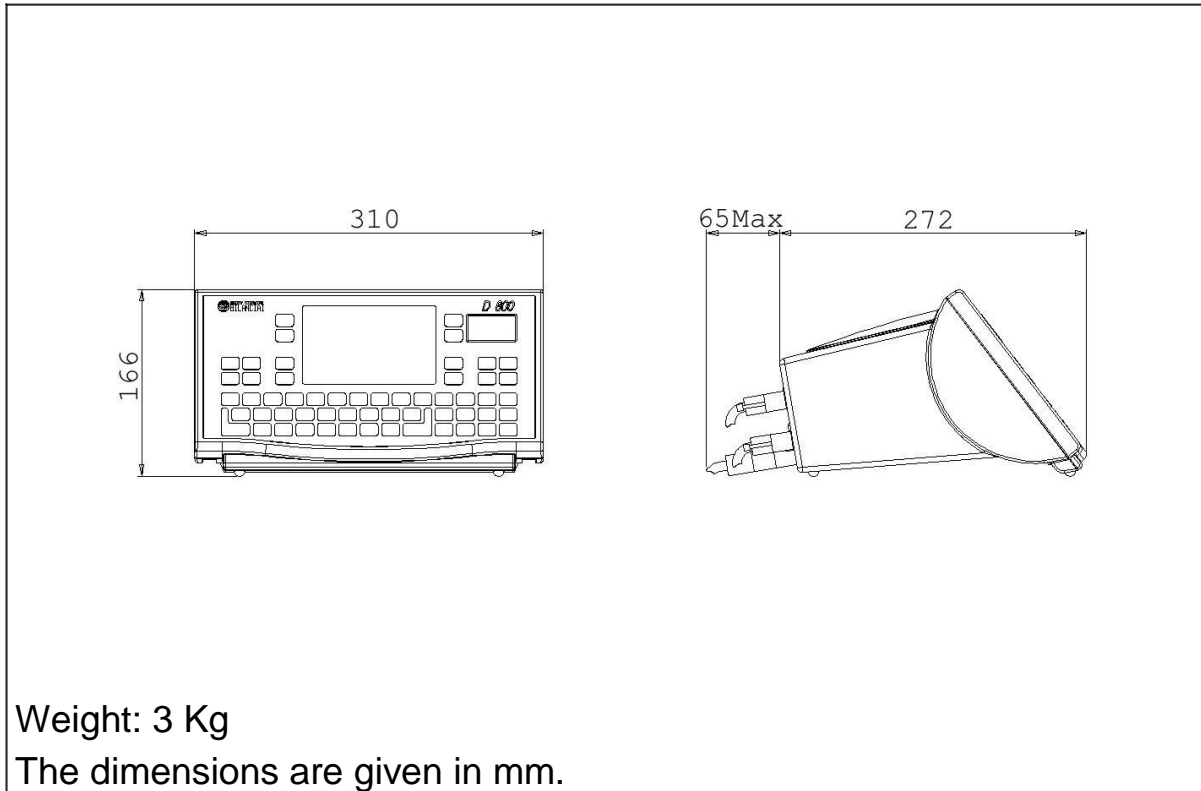

Weight: 3 Kg

The dimensions are given in mm.

Figure 1.1 - Dimensions and weight of table top version  
(citi0401.jpg)

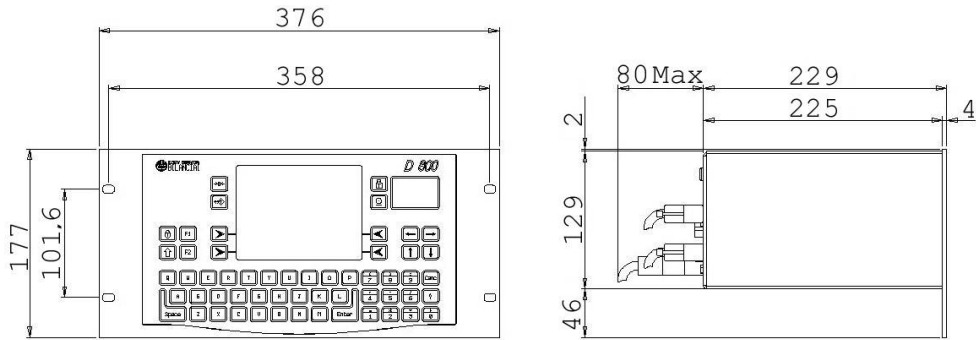

Weight: 4 Kg

The dimensions are given in mm.

Figure 1.2 - Dimensions and weight of rack-mounted version (citi0402.jpg)

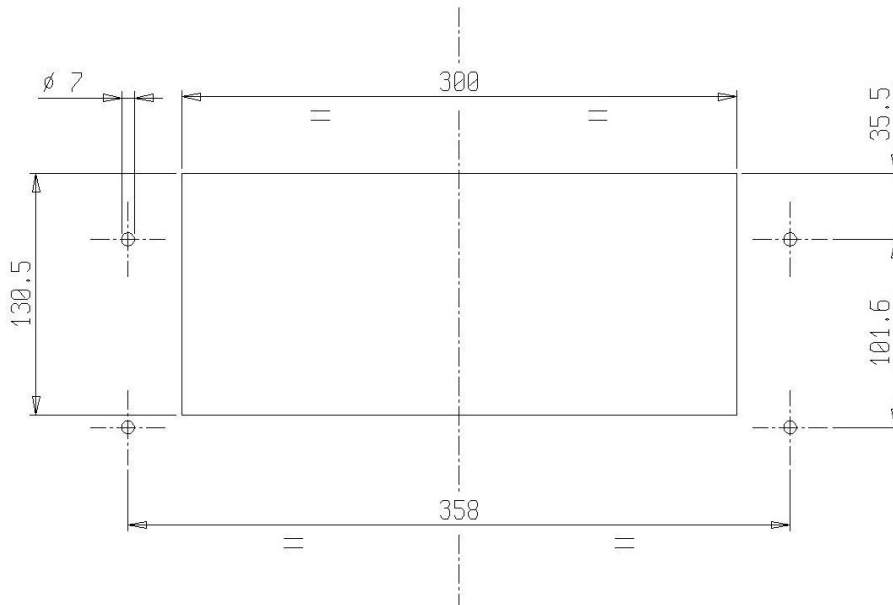

The dimensions are given in mm.

Figure 1.3 - Panel drilling measurements for rack-mounted version (citi0403.jpg)

## 1.8 Obtaining technical assistance

In the event of any operating faults requiring the intervention of specialised technicians, contact the manufacturer or your nearest Service Centre. To enable us to deal with your request swiftly, always quote the serial number of your terminal, which can be found on the seal label. Also provide information about the system in which the terminal is installed.

## 1.9 Replacement parts list

Replacement parts can be ordered directly from the manufacturer or from your nearest Service Centre.

Code	Description
460727	110/240 Vac power supplier
460740	12-24 Vdc-ac power supplier
169378	Keypad unit for table top version
169393	Keypad unit for rack mounted version
512738	PS2 keyboard (it)
404021	CPU board
460728	Converter for analogue load cells
403961	Interface for digital load cells
403981	MPP FLASH memory expansion board
403991	Serial expansion board
404001	Board with 4 inputs / 4 outputs
404061	Board with 4 inputs / 12 outputs
404521	DIWIFI card
404523	DINET ethernet card 10/100 Mbit/s, TCP/IP, UDP
404231	Ethernet card 10 Mbit/s, TCP/IP, UDP, FTP + RS232 modem
404011	BCD TTL or calculator board
404012	BCD 24V source board
527313	Internal lithium battery
528240	Display
520534	Inverter for display
475052	STB112 standard printer connection cable

### 1.10 Warranty

The conditions of warranty are stipulated in the contract of sale.



## 2. SAFETY INSTRUCTIONS

### 2.1 Prohibited uses

The instrument you have purchased is a weighing system and has been designed and manufactured as such. The instrument is primarily intended for the weighing of goods.

- ✓ It is forbidden to use the terminal without taking the necessary precautions for safe use.
- ✓ Use of the terminal in places with potentially explosive atmospheres or in areas where there is a risk of fire is strictly prohibited.

Any other use shall only be permitted if expressly authorised by the Manufacturer.

### 2.2 Regulations

The operating conditions for the electronic terminal are subject to the regulations in force in the country in which the terminal is used. All use of the terminal in conditions which do not comply with these regulations is prohibited.

### 2.3 Prescriptions of use

- ✓ Strictly comply with the instructions in this manual during use.
- ✓ In the event of any discrepancy between the information in this manual and the instrument purchased, contact your Dealer or the Manufacturer's After-Sales Service for clarification.
- ✓ Always observe the indications given on the warning and danger plates on the terminal.
- ✓ Check that all the safety guards are in place and that the connection cables are in good condition and connected correctly.
- ✓ Check that the terminal is connected to an electrical outlet socket equipped with an effective earth connection. Make sure that the line complies with the applicable regulations. Check that there is no difference in potential between the earth and neutral conductors.
- ✓ If the terminal is to be connected to other devices (e.g. a computer), these devices must be disconnected from the electrical supply before connection to the terminal.

- ✓ All maintenance and/or repairs must be carried out by authorised personnel only.
- ✓ Always disconnect the terminal from the electrical supply and wait a few minutes before accessing the internal components.

### 3. DELIVERY AND INSTALLATION

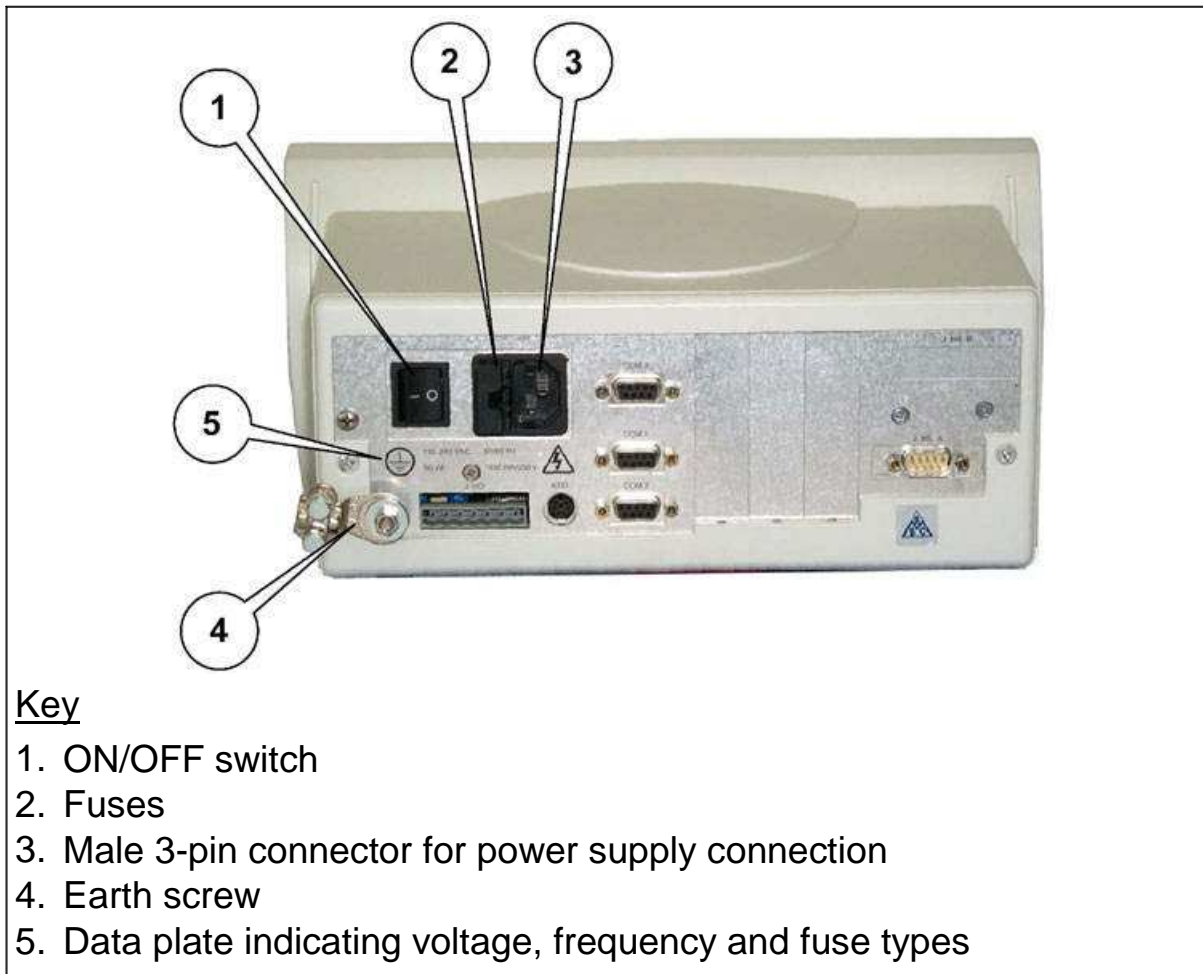

#### Key

1. ON/OFF switch
2. Fuses
3. Male 3-pin connector for power supply connection
4. Earth screw
5. Data plate indicating voltage, frequency and fuse types

Figure 3.1 - Rear of terminal (powering part) (citi0404.jpg)

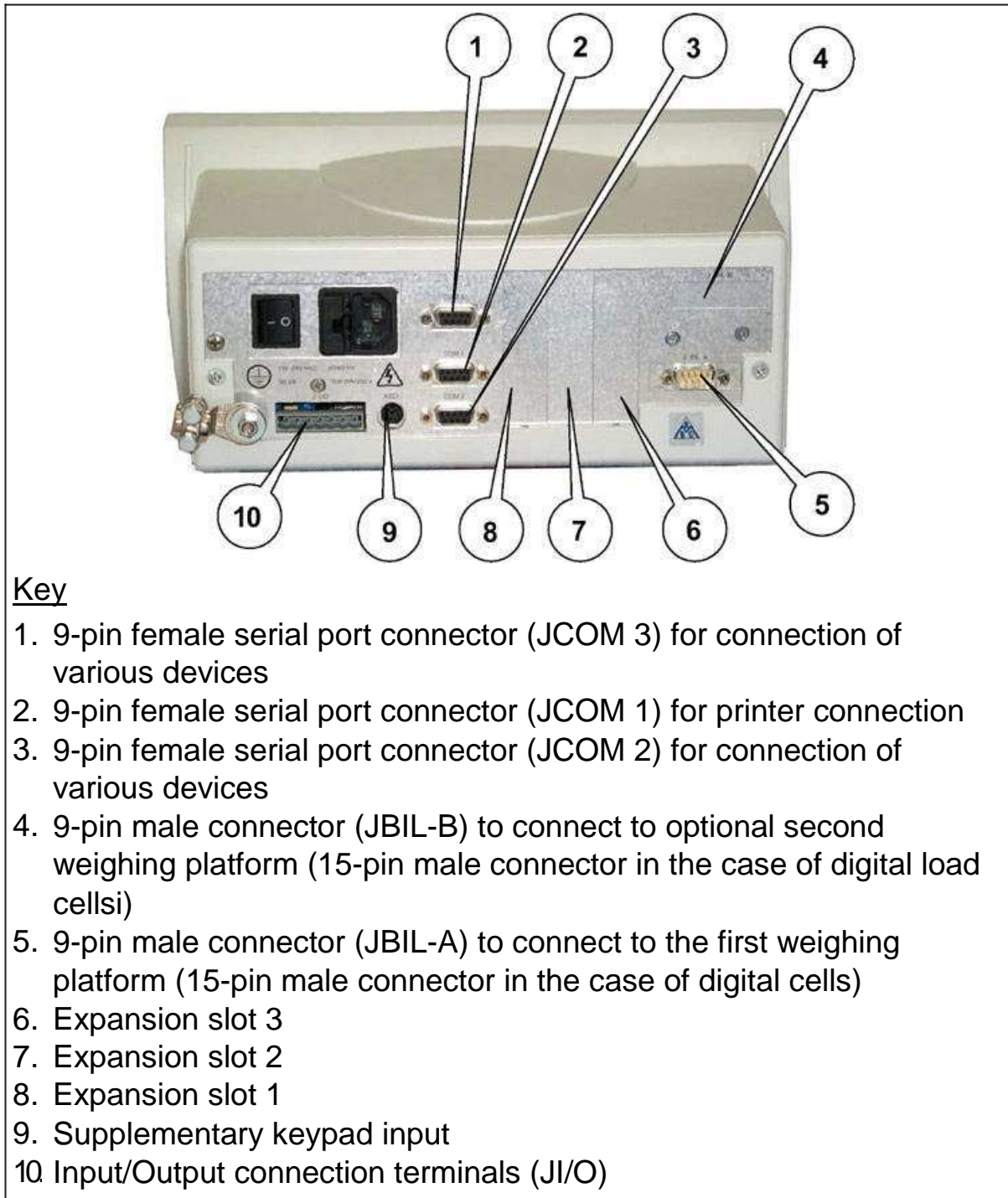

Figure 3.2 - Rear of terminal (part connecting to scale and auxiliary outputs) (citi0405.jpg)

### 3.1 Connection of the terminal to the electrical supply line



Check that:

- ✓ The voltage and frequency of the electrical supply line corresponds to the indications on the warning plate on the rear of the terminal (see point 5 Figure 3.1 on page 1-21 );
  - ✓ the mains outlet socket to which the terminal is connected is equipped with an earth;
  - ✓ the warning and danger signs are present and legible;
  - ✓ failing this, notify your maintenance personnel or contact our Assistance Service directly;
- 

For the correct connection of the terminal to the electrical supply line, proceed as follows:

- ✓ plug the 3-pin connector of the power lead into the connector on the rear of the terminal;
- ✓ insert the plug of the power lead into the correct mains outlet socket.

The terminal complies with the European Directive for electromagnetic compatibility, however it is good practice to provide a separate power supply line for the terminal.

---

 **WARNING** 

---

Do not route the terminal connection cables alongside power cables as these could cause disturbances that interfere with the correct operation of the terminal. Only use the connection cable supplied with the terminal. If the cable supplied is too short, do not attach an extension lead but contact the Manufacturer.

---

### 3.2 Connection of the terminal to the platform scale

The terminal is normally supplied with a pre-wired cable for connection to the platform scale. The female connector on this cable should be plugged into the male 9/15-pin connector (JBIL1 or 2) on the rear of the terminal (see point 5 Figure 3.2 on page 1-22 ). The connection method may vary according to the type of transducer on the platform scale (analogue or digital). If the scale is the duplex type, scale A should be connected to connector JBIL1 and scale B to connector.

---

 **WARNING** 

---

The cable screen should always be connected to the metal cap of the 9/15-pin connector. Do not route the scale connection cable alongside power cables.

---

### 3.2.1 Equipotentiality between the terminal and the platform scale

Check that a condition of equipotentiality exists between the metal parts of the terminal and the platform scale.

If in doubt, connect the terminal and the scale using a earth wire of at least 6mm<sup>2</sup> using the earth screw on the rear of the terminal (see point 4 Figure 3.1 on page 1-21 ).

The cables required for this connection are to be provided by the customer.

### 3.2.2 Connection of analogue load cells

The diagram below shows the pinout for the JBIL connector for connection to scales with analogue load cells.

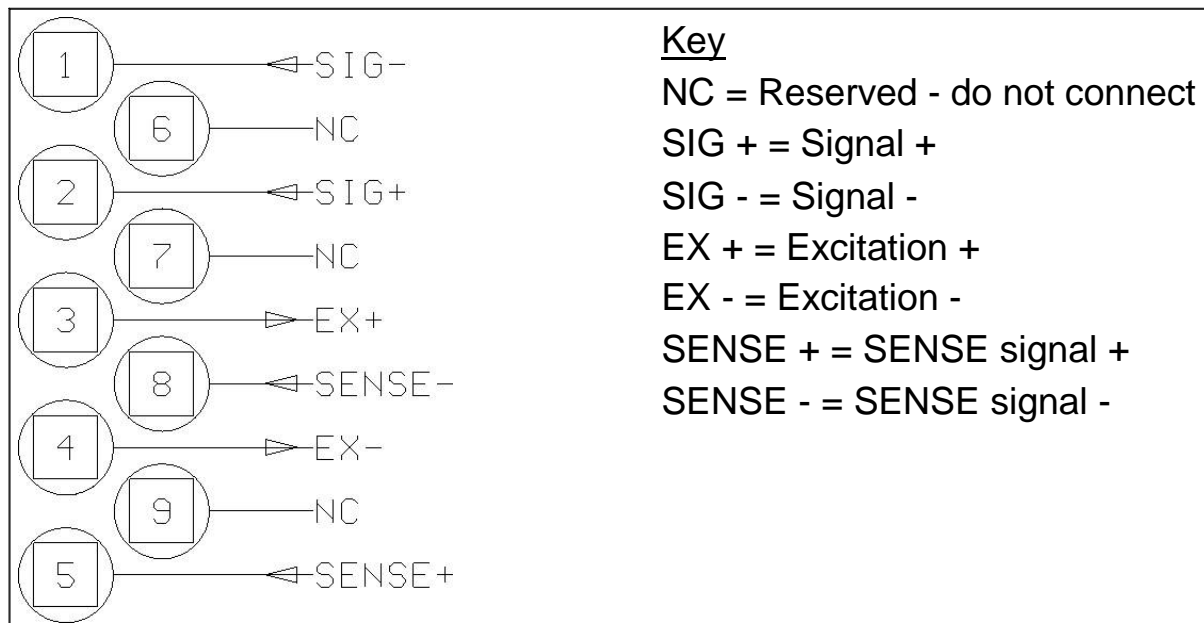

Figure 3.3 - Pinout for the JBIL connector for connection to scales with analogue load cells (log0001.gif)

### 3.2.3 Connection of digital load cells

Connection to digital load cells is by RS485 serial line using a screened cable with 6 conductors. The diagram below shows the pinout of the JBIL connector for connection to platform scales with digital load cells.

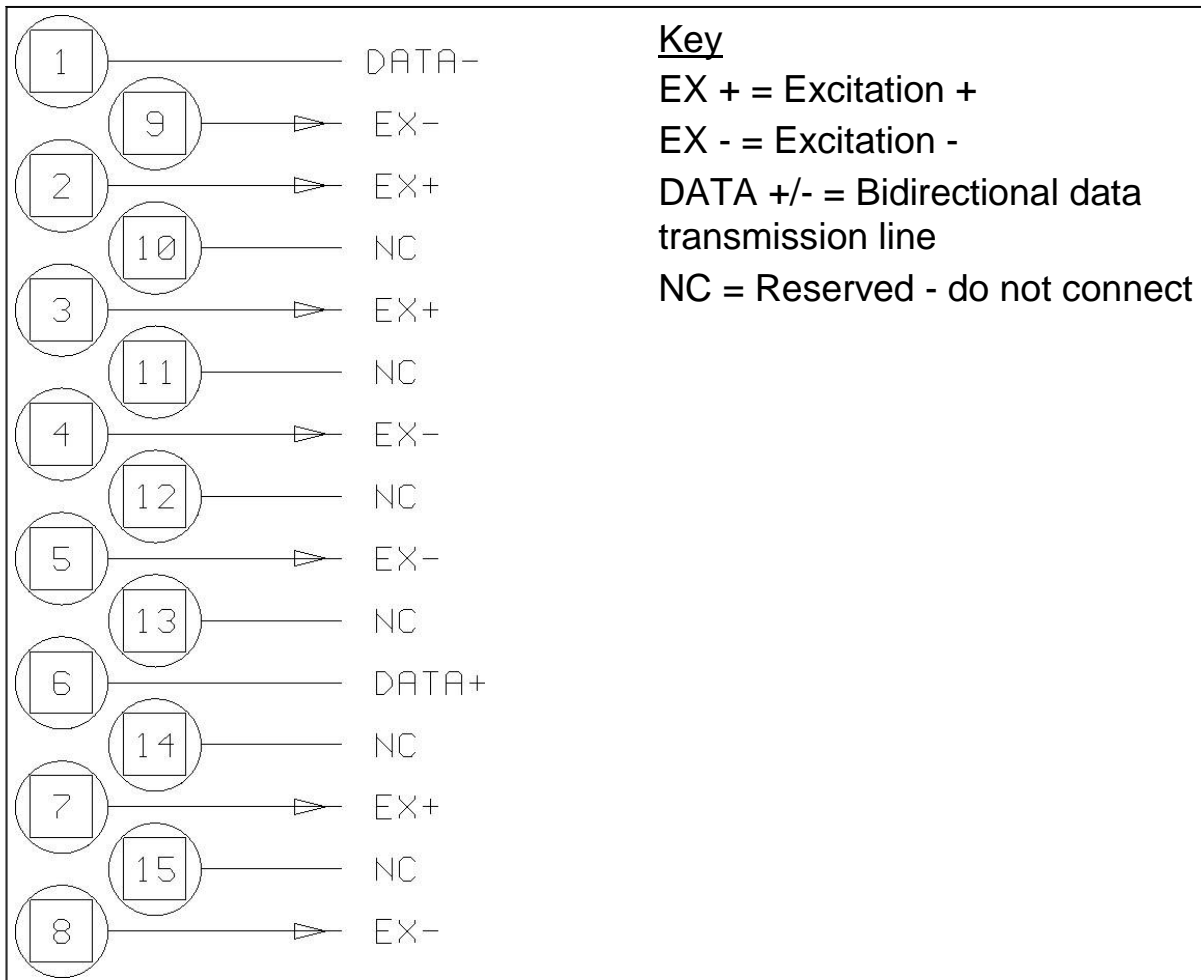

Figure 3.4 - Pinout of JBIL connector for connection to scales with digital load cells (log0002.gif)

Pins carrying the same signals may be connected in parallel.

### 3.3 COM1 serial port connection

The terminal has an RS232 serial port (COM1) with a 9-pin female connector located on the rear panel (see point 2 Figure 3.2 on page 1-22); the diagram below shows the pin connections for this port.

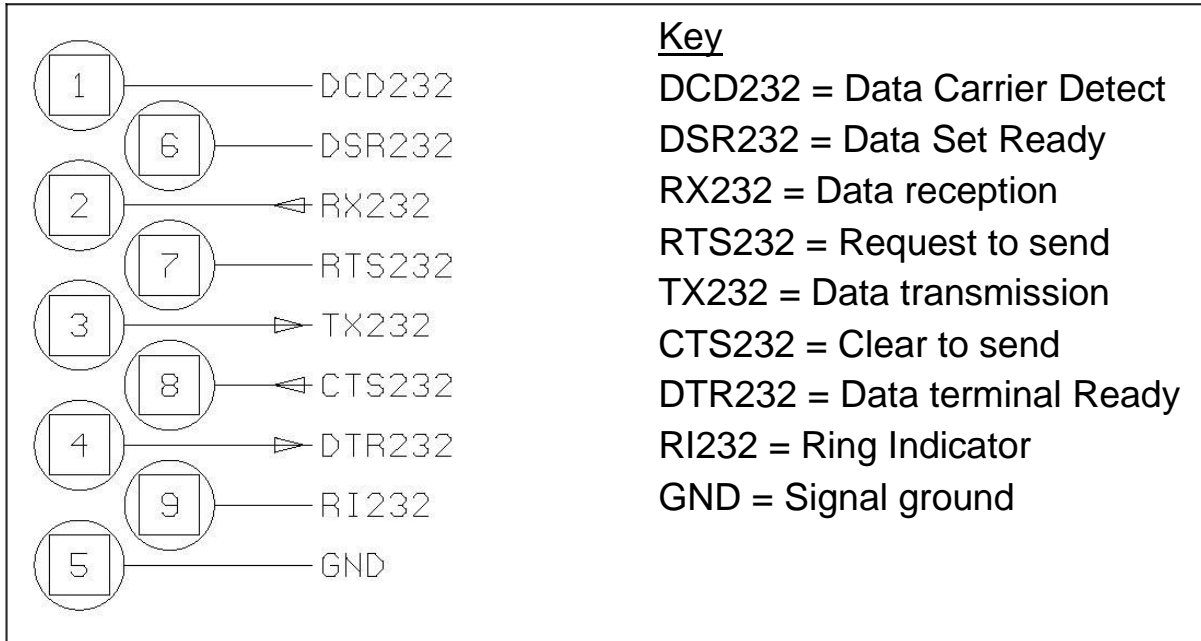

Figure 3.5 - Standard serial port connector (9-pin female D-type)  
(citi0406.gif)

### ⚠ CAUTION ⚠

Operating limits stipulated by the standard RS232:

Maximum transmission distance = 15 m

Maximum line voltage =  $\pm 12$  Vdc

For connection to external devices, use a screened cable and connect the screen to the metal cap of the 9-pin connector.

### 3.4 COM2 serial port connection

The terminal has second serial port, which can be configured for RS232, RS422 or RS485 data transmission standards. The serial port (COM2) has a 9-pin female connector (see point 3 Figure 3.2 on page 1-22 ).

#### 3.4.1 Connection of COM2 in RS232 configuration

For the connection of external devices, refer to the pinout diagram in Figure 3.6 on page 1-28 :

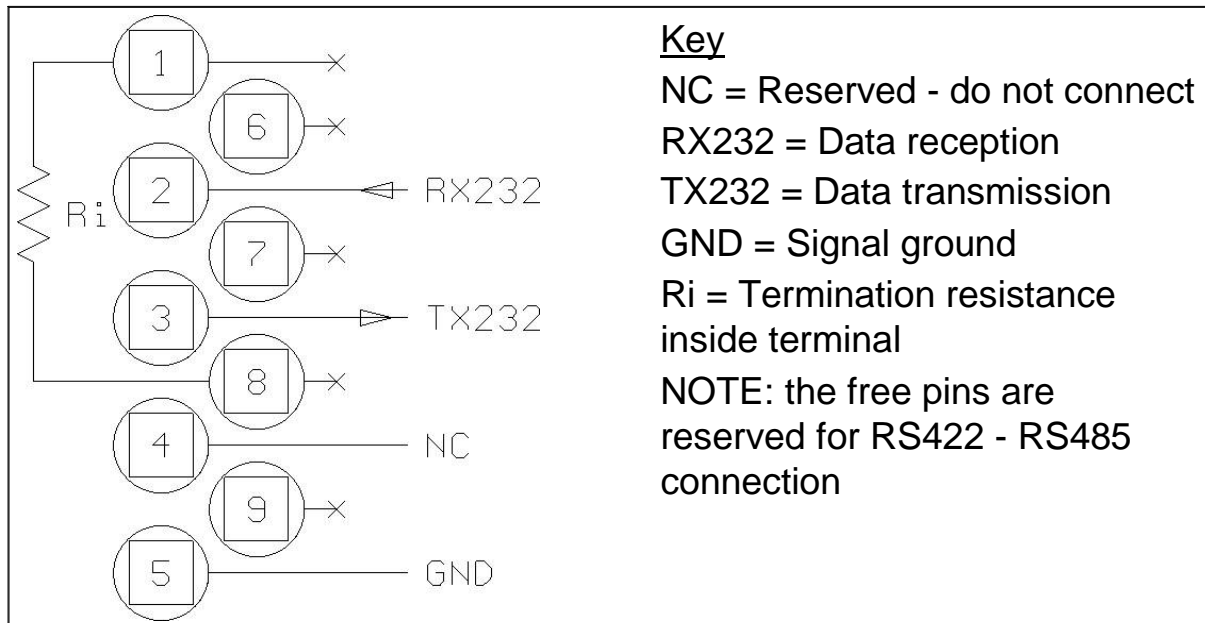

Figure 3.6 - COM2 serial port connector (9-pin female D-type)  
 (log0004.gif)

### ⚠ CAUTION ⚠

The RS232 operating limits are indicated in par. 3.3 on page 1-27.

### 3.4.2 Connection of COM2 in RS422 configuration

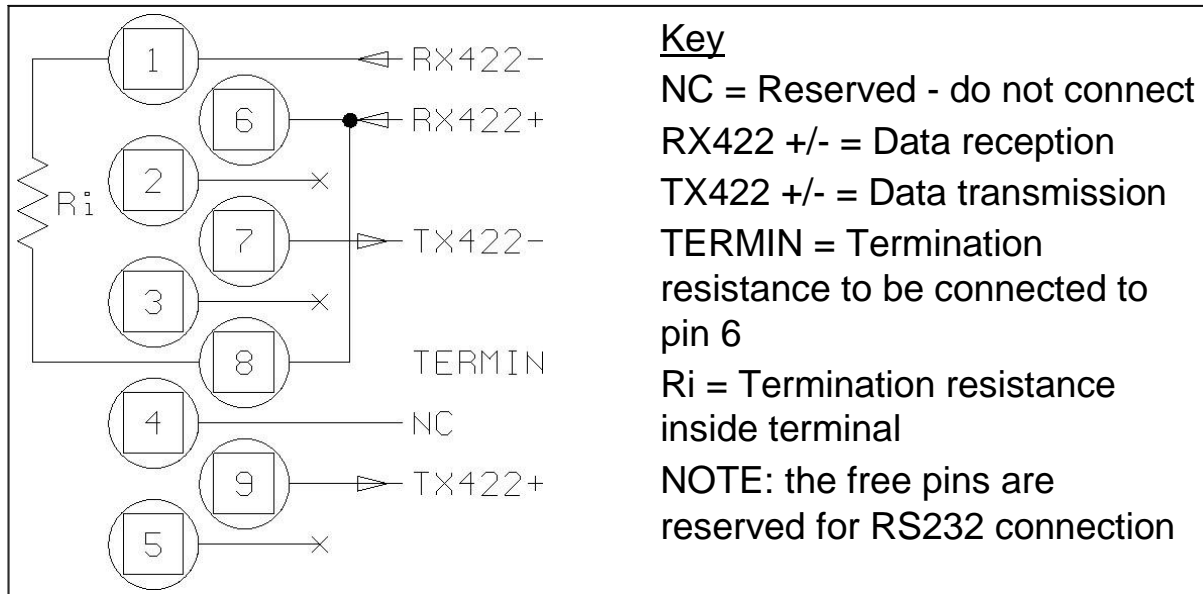

Figure 3.7 - Example of RS422 serial port connection (log0005.gif)

## ⚠ CAUTION ⚠

Operating limits stipulated by the standard RS422:

Maximum transmission distance = 1200 m

Maximum line voltage = +/- 7V

For connection to external devices, use a screened twisted pair cable and connect the screen to the metal cap of the 9-pin connector.

### 3.4.3 Connection of COM2 in RS485 configuration

If the COM2 serial port is configured for RS485 data transmission, you will need to:

- ✓ connect together pins 9 and 6 and pins 1 and 7 ( Figure 3.8 on page 1-30)
- ✓ place a jumper across pin 6 and pin 8 to connect the termination resistance; this operation is to be carried out on the first and last terminals connected in the line

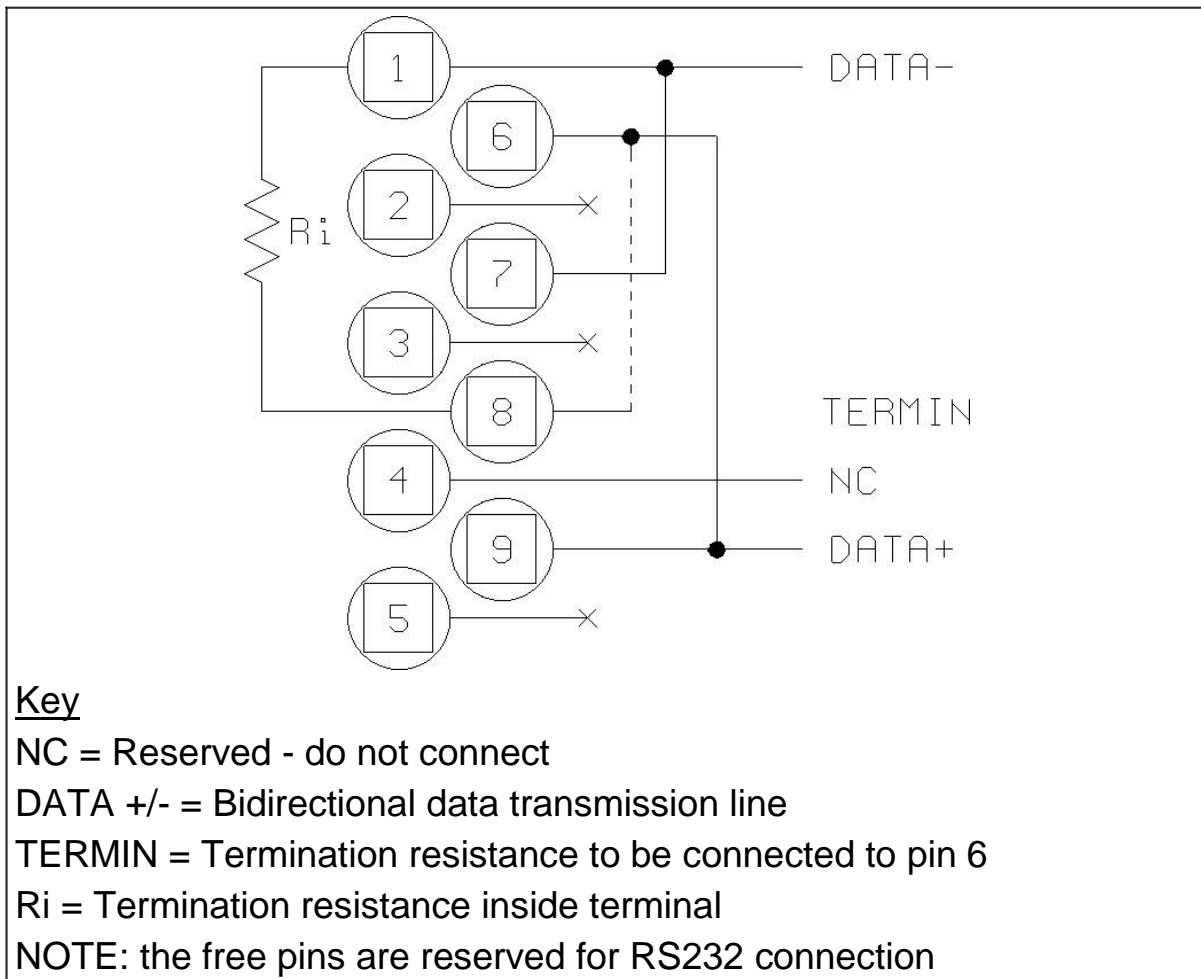

Figure 3.8 - Pinout for RS485 serial port connection (log0006.gif)

---

** CAUTION **

---

Operating limits stipulated by the standard RS485:

Maximum transmission distance = 1200 m

Maximum line voltage = +/- 7V

For connection to external devices, use a screened twisted pair cable and connect the screen to the metal cap of the 9-pin connector.

Maximum number of terminals that may be connected = 16

---

### 3.5 COM3 serial port connection

The terminal is equipped with a third serial output as part of standard supply (COM3). For connections, refer to par. 3.4 on page 1-28 . The pin numbers are the same.

### 3.6 External keypad connection

An input for a compatible PC keyboard is available in the KBD connector at the rear of the terminal (point 9 of Figure 3.2 on page 1-22 ).

---

** CAUTION **

---

Use of the external keyboard inhibits COM2 operation.

---

### 3.7 Printer connection

Unless different instructions are given, the external printer is connected to the COM1 serial port of the terminal using the supplied cable.

### 3.8 Input/Output connection

The terminal board JI/O on the rear of the instrument (point 10 Figure 3.2 on page 1-22 ) provides input and output contacts; Figure 3.9 on page 1-32 contains the pinout diagram.

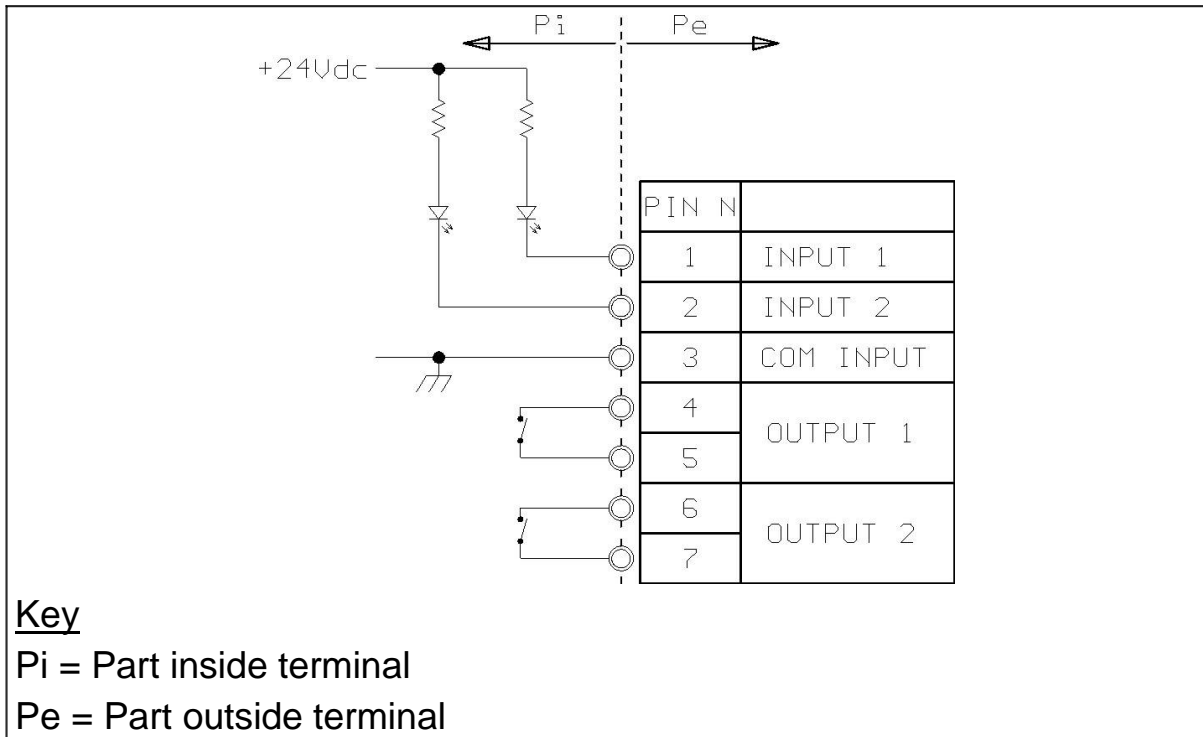

Figure 3.9 - JI/O terminal board for Input/Output connections (log0008.gif)

---

 CAUTION 

---

Technical characteristics:

Input:

Maximum input voltage = 24Vdc

Maximum input current = 5mA

The inputs can be controlled by a mechanical contact or by an NPN-type transistor (negative common)

Output:

mechanical voltage-free contact

Maximum switchable voltage = 110 Vac/dc

Maximum switchable current = 200 mA

I/O refresh time = 0.1s

---

---

 DANGER 

---

When the weighing system is installed in complex plants that can represent a danger hazard for operators, enlist the assistance of specialised personnel to perform several manoeuvres without load in order to acquire the experience necessary to work in safety.

---



## 4. CONTROLS, DISPLAY, SWITCHING THE TERMINAL ON AND OFF

### 4.1 Display of weight and additional information

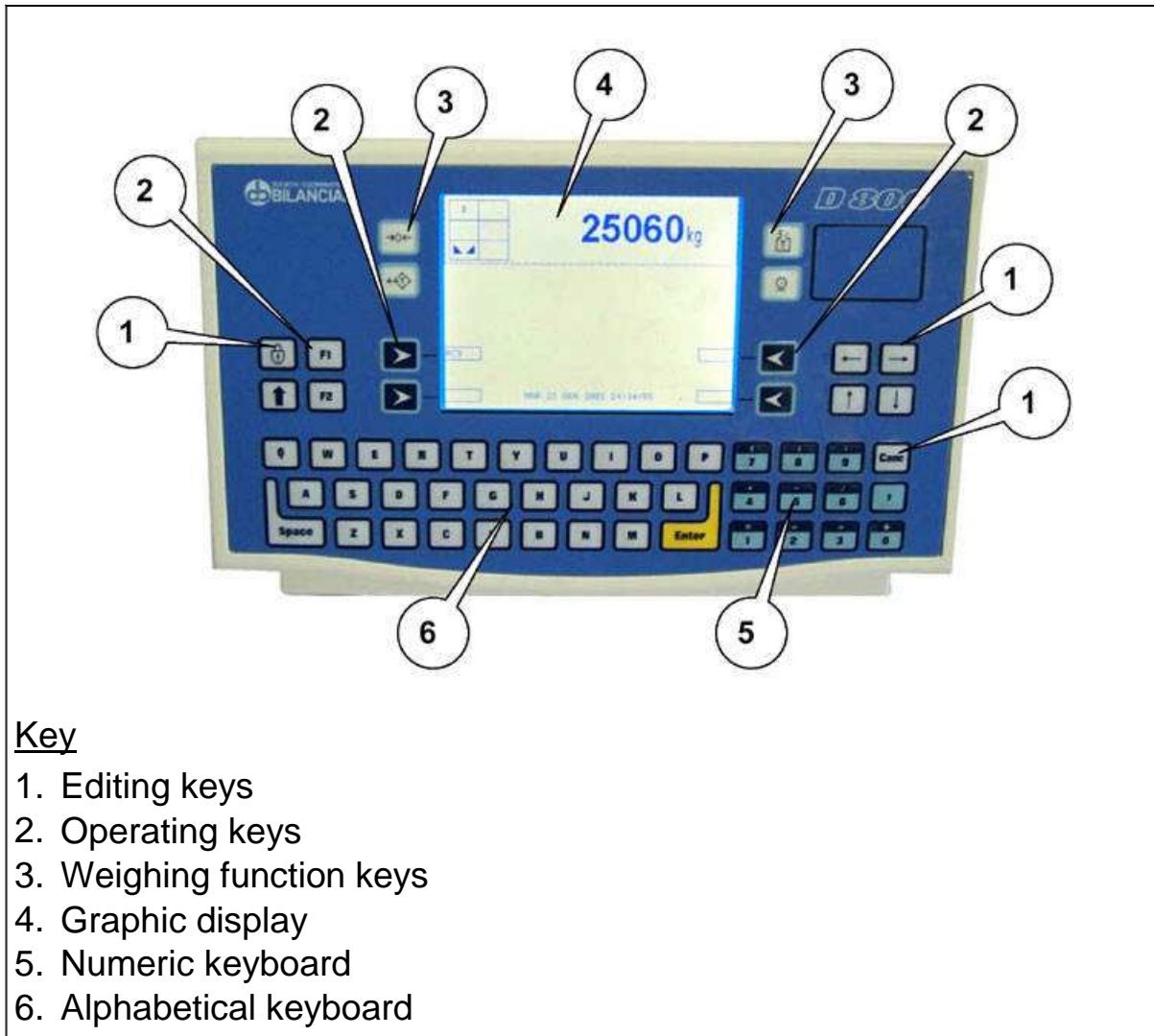

#### Key

1. Editing keys
2. Operating keys
3. Weighing function keys
4. Graphic display
5. Numeric keyboard
6. Alphabetical keyboard

Figure 4.1 - Front of terminal (citi0407.jpg)

The LCD (Liquid Crystal Display) (point 4 Figure 4.1 on page 1-35 ), in addition to the universally recognised weighing symbols, also displays information (in extended format) related to the operation of the terminal.

Listed below are the weighing symbols displayed and their meanings:



Weight stable symbol

Indicates that the weight value displayed is stable and thus may be printed and/or transmitted.



Centre zero symbol

Indicates that the weight on the scale is near to zero i.e. within  $-1/4 + 1/4$  of a division.



Tare symbol

Indicates the presence in memory of an acquired tare value.



Preset tare symbol

Indicates that a tare value has been entered from the keypad.



Gross weight symbol



Gross weight symbol with units of measurement in lb (as alternative to B)

This symbol only illuminates when the unit of measurement is "lb" (pounds).



Minimum weight



Net weight symbol



Weighing range indication for multi-extension (ME) instruments

#### 4.1.1 Selection display symbols

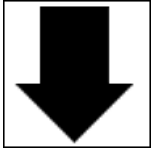

Weight indication  
Below preset lower limit.

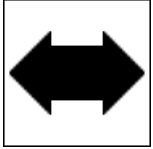

Weight indication  
Within the preset upper and lower limits.

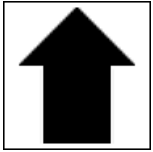

Weight indication  
Above the preset upper limit.

## 4.2 Weighing function keys

Refer to points 3 of Figure 4.1 on page 1-35 :



### Zero-set weight

press this key to reset the weight indication only in the presence of the following condition:

- ✓ the weight value must be within the -1% to +3% range of the weighing capacity for terminals subject to legal verification or  $\pm 50\%$  for other terminals;
- ✓ the weight must be stable;
- ✓ no tare must have been entered.



### Enter/cancel tare

On pressing this key, the weight on the scale is acquired as the tare value, provided the following conditions are satisfied:

- ✓ the weight must be stable;
- ✓ the weight must have a positive value;
- ✓ the weight must not exceed the maximum capacity.

Symbols **NET** and  appear on the display.

On MD terminals, the weight indication will be displayed using the division of the lower range. On ME terminals, the net weight will be displayed using the division of the range in within which it falls.

On pressing  again, the tare will be cancelled and the terminal will display the gross weight again.



### Enter/display tare

Pressing this key allows you to enter a tare value using the numeric keys on the keypad. To change a preset tare value see par. 5.4.27 on page 1-75 .

On completion of the operation, the display will show the net weight, tare values and symbols

**NET** and **PT** will appear. The entered tare value will be automatically rounded off to the nearest scale division. On MD terminals, the net weight will be displayed using the division of the range within which the net weight value falls, while on ME terminals, the net weight division shall be that of the range within which the gross weight falls. On MD terminals, the maximum preset tare value is limited to the maximum capacity of the first weighing extension (indicated on the metrological data plate).



### Print and/or send

Allows a weighing option to be requested. Consequently forces a weighing data printout and/or serial transmission of a string of data via the configured port.

### 4.3 Operating keys

Refer to points 2 of Figure 4.1 on page 1-35 :



Customizable keys

The function associated with these keys appears on the display.



Function keys

These keys access functions that can be called up from the numeric keyboard.



The functions of all the keys may change. These changes are indicated by messages on the display.

### 4.4 Editing keys

Refer to points 1 of Figure 4.1 on page 1-35 :



Cursor keys

Press these keys to move the cursor around the display.



**Caps key**

Allows capital letters to be entered when used in combination with the alphabet keys.

Allows special characters and punctuation marks to be entered when used in combination with the numeric keys.

**Cancel key**

Allows the newly entered character to be cancelled.

**Caps Lock**

Allows the operator to write in capital letters.

## 4.5 Numeric keyboard

Refer to point 5 of Figure 4.1 on page 1-35 :

**Numeric keys (0...9).**

Press these keys to enter numeric characters or symbols.

**Comma key**

This key is used to enter commas in alphanumerical descriptions.

It is also used to enter the decimal separator symbol in numeric values.

In this case, it enters the decimal separation symbol selected during the configuration phase (dot or comma).

## 4.6 Alphabetical keyboard

Refer to point 6 of Figure 4.1 on page 1-35 :



Alphabet keys (A...Z)

These normally enter lower case characters. For

capital ones, press .



Enter key

Used to send or confirm a data item

Owing to printing requirements, this key will be

indicated in the manual by 

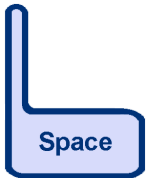

Space key

Space key.

Owing to printing requirements, this key will be

indicated in the manual by 

## 4.7 External keyboard (optional)

F1-F2: operate in the same way as the key on the panel

F3-F8: Shortcut keys programmable in setup mode (\*)

F9 : key  (point 1 of Fig. 4.2 on page 1-43 )

F10: key  (point 2 of Fig. 4.2 on page 1-43 )

F11: key  (point 4 of Fig. 4.2 on page 1-43 )

F12: key  (point 3 of Fig. 4.2 on page 1-43 )

Print: same as print key

Arrows up, down, right, left ( $\uparrow$ ,  $\downarrow$ ,  $\rightarrow$ ,  $\leftarrow$ ): operates in the same way as the key on the panel

Page up, Page down: page change during list display

Home, End: go to beginning/end of the table during list display (\*)

Canc: operates in the same way as the key on the panel

Backspace: operates in the same way as canc

Shift, Caps lock, Num lock: operate in the same way as a normal PC keyboard

Double function alphabetical keys with double functions, punctuation characters: same operation as a normal PC keyboard with the exclusion of the characters entered by pressing key Alt Gr or Alt + ASCII code

Tab, Esc, Ins, Scroll lock, Pause/Interr: not used

(\*) function not currently available



Figure 4.2 - Customizable keys (citi0412.jpg)

## 4.8 Switching the terminal on and off



### Key

1. ON/OFF switch

Figure 4.3 - On/Off switch (citi0408.jpg)

## **⚠ DANGER ⚠**

Before switching on the terminal, check that the safety guards are in place and in good working order.

If the terminal is wall mounted on an electrical panel, there must be a main switch that disconnect powers to the entire panel.

To identify this switch, contact your internal maintenance manager.

Press the switch on the rear of the terminal (see point 1 Figure 4.3 on page 1-44 ) and move it to position:

- I to switch on the terminal;
- O to switch it off

When powered, the display will show the Manufacturer's logo and the type of operation for which the terminal is enabled (see par. 5.1.5 on page 1-49 ).

Wait for the LOCK indication to appear (terminals subject to metrological verification only).

If on completion of the operation the display shows a value other than

zero , press  to zero-set the reading.

If the display is not zero-set on pressing the key:

- ✓ check that the platform scale is in fact unloaded. If not, unload the scale, switch off the terminal and then switch it on again;
- ✓ If the problem persists, contact your Service Centre.







## 5. USE OF THE TERMINAL

### 5.1 General

#### 5.1.1 Using the keys to browse the menus

The operating keys described in par. 4.3 on page 1-40 allow you to browse through the programming menus.

From the normal display status, you can access the menus by using

keys  (or ) +  (point 2 of Fig. 4.2 on page 1-43) to select the MENU item. After this, the other keys can be used to select the next data item. The arrows in the menu ,  allow you to move up and down, respectively.

Use key  to select the item required or to access a sub-menu.

Keys # and \ can be used to change the mode in which the menu path is displayed : # path in full, \ path expressed in numbers.





Select item ESC to return to the previous menu level. From here on in this manual, the instructions will only indicate the pathway without referring to the specific keys to be pressed. For example, the instruction on how to change the contrast will be given as follows:

```
...>MENU>Contrast>+ or - >SAVE>ESC
```

#### 5.1.2 Access to the functions

To access the functions, use:

✓ keys , , ,  at the sides of the display that indicate the function;

✓ keys  and  followed by a number. The number to press appears on the display after  or  have been pressed.

### 5.1.3 Special characters

Prolonged pressure on a key will display the special character associated with it. A list of the special characters associated with the alphanumerical keys is given in the table below.

Alphanumeric keys	Characters
Key 0	? ¿
Key 1	! ¡
Key 2	Pt f
Key 3	£
Key 4	\$
Key 5	%
Key 6	&
Key 7	[ { <
Key 8	] } >
Key 9	;
Key ,	. @
Key A	â ä à å Ä Å <sup>a</sup>
Key C	ç Ç
Key E	é ê ë è É æ Æ
Key I	ï î ï í
Key N	ñ Ñ
Key O	ô ö ò ó Ö °
Key S	ß
Key U	ü û ù ú Ü
Key Y	ÿ

Keep any one of the alphanumeric keys depressed for one second to call up one of the alternative special characters. Wait one and a half seconds to confirm the special character. To scroll through all the special characters associated with a given alphanumeric key, repeatedly press the key itself.

#### 5.1.4 Shortcut keys

During installation, User menu functions may be assigned to shortcut keys. In this way the user can access the required function more rapidly. For example, to access the Product Code function, there is no need to press:

```
...>MENU>Totals Management>Total for Client Code  
simply press CLTOT.
```

The abbreviations that appear on the display may be customised during installation. For this reason, the abbreviations related to the shortcut keys that appear in brackets alongside or below the pathways described in the following paragraphs may have been modified by the installer. Ask your installer for a list of the abbreviations and their meanings.

#### 5.1.5 Operating modes

The terminal can operate in two different modes which also possess further variants to adapt to different weighing requirements. The two main operating modes are: single weighing (described in chap. 6. on page 1-83 ) and double weighing (described in chap. 7. on page 1-87 ). The operating mode of the terminal is selected during the installation phase and appears on the display when the instrument is powered.

## 5.2 User menu

To access the user menu, press **F1** (or **F2**) immediately followed by MENU.

### 5.2.1 User Menu tree for single weighing mode operation

The user menu tree expanded to the third level is given below. Refer to the subsequent paragraphs for details about the various functions (from par. 5.4.6 on page 1-66 to par. 5.4.33 on page 1-81 ).

#### Scale selection

- A
- B
- C
- A+B
- A+C
- B+C
- A+B+C

#### Data management

- Codes management
  - Product Code List
  - Client Code List
  - Generic Code List
  - TCA Code List

#### Range

- Range 01
- Range 02
- Range 11
- Range 12
- Range 13
- Range 14
- Range 21
- Range 22
- Range 23
- Range 24
- Range 31
- Range 32
- Range 33
- Range 34

#### Setpoint

- Setpoint 01
- Setpoint 02
- Setpoint 11
- Setpoint 12
- Setpoint 13
- Setpoint 14
- Setpoint 21
- Setpoint 22
- Setpoint 23
- Setpoint 24
- Setpoint 31

- Setpoint 32
- Setpoint 33
- Setpoint 34
- Range on Display
- Display MPP data
- Preset tares
  - Preset Tares List
  - Preset Tares List 1
  - Preset Tares List 2
  - Number of Packs
- Progressive N.
- Coefficient management
  - Coefficient
  - Coefficient value
  - Max.Coefficient (or Min.Coefficient)
  - Operation
  - Result
- Modifiable Archives
- Totals management
  - General Total
  - Partial Total
  - Product Code Total
  - Client Code Total
  - Generic Code Total
  - TCA Total
  - Weight sum report
  - Journal Entry Total
- MPP operation
  - De-activated
  - With memory
  - With printer
- Display
  - 12 mm digits
  - Selection
  - Display tare
- Contrast
- Lighting
  - Always
  - Timed
- Memory Status
- Reprint
- Date Time
- Diagnostics A
- Diagnostics B
- Customizable fields
  - Field 1
  - Field 2
  - Field 3
  - Field 4
  - Field 5
  - Field 6
  - Field 7
  - Zero set
- Cut printer paper
- High resolution

## 5.2.2 User Menu Tree for double weighing mode operation

### Scale selection

- A
- B
- C
- A+B
- A+C
- B+C
- A+B+C

### Data Management

- Codes management
  - Product Code List
  - Client Code List
  - Plate Codes List
  - RCD List
  - RCD Plate List
  - RPD List
  - RPD Plate List

### Range

- Range 01
- Range 02
- Range 11
- Range 12
- Range 13
- Range 14
- Range 21
- Range 22
- Range 23
- Range 24
- Range 31
- Range 32
- Range 33
- Range 34

### Setpoint

- Setpoint 01
- Setpoint 02
- Setpoint 11
- Setpoint 12
- Setpoint 13
- Setpoint 14
- Setpoint 21
- Setpoint 22
- Setpoint 23
- Setpoint 24
- Setpoint 31
- Setpoint 32
- Setpoint 33
- Setpoint 34

### Display MPP data

- Progressive N.

### Coefficient management

- Coefficient
- Coefficient value
- Max.Coefficient (or Min.Coefficient)
- Operation
- Result

- Modifiable Archives
- Totals management
  - General Total
  - Partial Total
  - Product Code Total
  - Client Code Total
  - Plate Total
  - RPD Total
  - Journal Entry Total
- MPP operation
  - De-activated
  - With memory
  - With printer
- Contrast
- Lighting
  - Always
  - Timed
- Memory status
- Reprint
- Date Time
- Diagnostics A
- Diagnostics B
- Customizable fields
  - Field 1
  - Field 2
  - Field 3
  - Field 4
  - Field 5
  - Field 6
  - Field 7
  - Zero set
- Cut printer paper
- High resolution

## 5.2.3 Complete User Menu Tree

### Scale selection

- A
- B
- C
- A+B
- A+C
- B+C
- A+B+C

### Data management

#### Codes management

- Product Code List
- Client Code List
- Generic Code List
- Plate Code List
- TCA Code List
- RCD List
- RCD Plate List
- RPD List
- RPD Plate List
- Supplier Code List
- Consignee Code List
- Product Code List
- Carrier Code List
- Plate Code List

#### Range

- Range 01
- Range 02
- Range 11
- Range 12
- Range 13
- Range 14
- Range 21
- Range 22
- Range 23
- Range 24
- Range 31
- Range 32
- Range 33
- Range 34

#### Setpoint

- Setpoint 01
- Setpoint 02
- Setpoint 11
- Setpoint 12
- Setpoint 13
- Setpoint 14
- Setpoint 21
- Setpoint 22
- Setpoint 23
- Setpoint 24
- Setpoint 31
- Setpoint 32
- Setpoint 33
- Setpoint 34

- Display Range
- Display MPP data
- Preset tares
  - Preset Tares List
  - Preset Tares List 1
  - Preset Tares List 2
  - Number of Packs
- Progressive N.
- Coefficient management
  - Coefficient
  - Coefficient value
  - Max.Coefficient (or Min.Coefficient)
  - Operation
  - Result
- Modifiable Archives
- Totals management
  - General Total
  - Partial Total
  - Product Code Total
  - Client Code Total
  - Generic Code Total
  - Plate Total
  - TCA Total
  - RPD Total
  - Weight sum report
  - Journal Entry Total
  - Supplier Code Total
  - Consignee Code Total
  - Product Code Total
  - Carrier Code Total
  - Plate Code Total
- MPP operation
  - De-activated
  - With memory
  - With printer
- Display
  - 12 mm digits
  - Selection
  - Display tare
- Contrast
- Lighting
  - Always
  - Timed
- Memory status
- Reprint
- Date Time
- Diagnostics A
- Diagnostics B
- Customizable fields
  - Field 1
  - Field 2
  - Field 3
  - Field 4
  - Field 5
  - Field 6
  - Field 7
  - Zero set

Cut printer paper  
High resolution

The user menu contains functions that are not normally associated with the shortcut keys. They can be associated during the installation phase. These functions are Display, Diagnostics, Change date and time and Memory status.

### 5.3 List of terminal functions

A list of the functions handled by the terminal along with the keys that allow them to be activated is given below. The functions have been divided per operating mode since different operating modes may correspond to different functions and/or different function activating procedures. Also remember that not all the functions can be accessed since their availability may depend on their having been activated when the terminal was configured.



Figure 5.1 - Customizable keys (citi0412.jpg)

### 5.3.1 Single weighing functions: standard



(point 1 of Fig. 5.1 on page 1-57 ) Customizable fields



(point 3 of Fig. 5.1 on page 1-57 ) Date time



(point 2 of Fig. 5.1 on page 1-57 ) Scale selection



(point 4 of Fig. 5.1 on page 1-57 ) Totals

- F1+0 General Total
- F1+1 Partial Total
- F1+2 Product Code Total
- F1+3 Client Code Total
- F1+4 Generic Code Total
- F1+5 ACT Total
- F1+6 Cut printer paper
- F1+7 MPP operation
- F1+8 MPP code
- F1+9 Progressive number

- F2+0 Reprint
- F2+1 Range
- F2+2 Set Point
- F2+3 Display range
- F2+4 Coefficient
- F2+5 Memory status
- F2+6 Contrast
- F2+7 Display
- F2+8 Field1
- F2+9 Field2

### 5.3.2 Single weighing functions: weight sum mode



(point 1 of Fig. 5.1 on page 1-57 ) Customizable fields



(point 3 of Fig. 5.1 on page 1-57 ) Weight Report



(point 2 of Fig. 5.1 on page 1-57 ) Scale selection



(point 4 of Fig. 5.1 on page 1-57 ) Totals

- F1+0 General Total
- F1+1 Partial Total
- F1+2 Product Code Total
- F1+3 Client Code Total
- F1+4 Generic Code Total
- F1+5 Date Time
- F1+6 Cut printer paper
- F1+7 MPP operation
- F1+8 MPP code
- F1+9 Progressive number

- F2+0 Reprint
- F2+1 Range
- F2+2 Set Point
- F2+3 Display range
- F2+4 Coefficient
- F2+5 Memory status
- F2+6 Contrast
- F2+7 Display
- F2+8 Field1
- F2+9 Field2

### 5.3.3 Single weighing functions: extraction



(point 1 of Fig. 5.1 on page 1-57 ) Customizable fields



(point 3 of Fig. 5.1 on page 1-57 ) Start/Stop



(point 2 of Fig. 5.1 on page 1-57 ) Scale selection



(point 4 of Fig. 5.1 on page 1-57 ) Totals

- F1+0 General Total
- F1+1 Partial Total
- F1+2 Product Code Total
- F1+3 Client Code Total
- F1+4 Generic Code Total
- F1+5 Date Time
- F1+6 Cut printer paper
- F1+7 MPP operation
- F1+8 MPP code
- F1+9 Progressive number

- F2+0 Reprint
- F2+1 Range
- F2+2 Set Point
- F2+3 Display range
- F2+4 Coefficient
- F2+5 Memory status
- F2+6 Contrast
- F2+7 Display
- F2+8 Field1
- F2+9 Field2

### 5.3.4 Double weighing functions: RCD + RPD



(point 1 of Fig. 5.1 on page 1-57 ) RPD



(point 3 of Fig. 5.1 on page 1-57 ) RCD



(point 2 of Fig. 5.1 on page 1-57 ) Scale selection



(point 4 of Fig. 5.1 on page 1-57 ) Totals

- F1+0 General Total
- F1+1 Partial Total
- F1+2 Product Code Total
- F1+3 Client Code Total
- F1+4 Plate Code Total
- F1+5 RPD total
- F1+6 Cut printer paper
- F1+7 MPP operation
- F1+8 MPP code
- F1+9 Progressive number

- F2+0 Reprint
- F2+1 Range
- F2+2 Set Point
- F2+3 Display range
- F2+4 Coefficient
- F2+5 Memory status
- F2+6 Contrast
- F2+7 Display
- F2+8 Date Time
- F2+9 Customizable fields

### 5.3.5 Double weighing functions: RCD Plate + RPD



(point 1 of Fig. 5.1 on RPD  
page 1-57 )



(point 3 of Fig. 5.1 on RCD Plate  
page 1-57 )



(point 2 of Fig. 5.1 on Scale selection  
page 1-57 )



(point 4 of Fig. 5.1 on Totals  
page 1-57 )

- F1+0 General Total
- F1+1 Partial Total
- F1+2 Product Code Total
- F1+3 Client Code Total
- F1+4 Plate Code Total
- F1+5 RPD total
- F1+6 Cut printer paper
- F1+7 MPP operation
- F1+8 MPP code
- F1+9 Progressive number

- F2+0 Reprint
- F2+1 Range
- F2+2 Set Point
- F2+3 Display range
- F2+4 Coefficient
- F2+5 Memory status
- F2+6 Contrast
- F2+7 Display
- F2+8 Date Time
- F2+9 Customizable fields

### 5.3.6 Double weighing functions: RCD + RPD Plate



(point 1 of Fig. 5.1 on RPD Plate  
page 1-57 )



(point 3 of Fig. 5.1 on RCD  
page 1-57 )



(point 2 of Fig. 5.1 on Scale selection  
page 1-57 )



(point 4 of Fig. 5.1 on Totals  
page 1-57 )

- F1+0 General Total
- F1+1 Partial Total
- F1+2 Product Code Total
- F1+3 Client Code Total
- F1+4 Plate Code Total
- F1+5 Customizable fields
- F1+6 Cut printer paper
- F1+7 MPP operation
- F1+8 MPP code
- F1+9 Progressive number

- F2+0 Reprint
- F2+1 Range
- F2+2 Set Point
- F2+3 Display range
- F2+4 Coefficient
- F2+5 Memory status
- F2+6 Contrast
- F2+7 Display
- F2+8 Date Time
- F2+9 Field1

### 5.3.7 Double weighing functions: RCD Plate + RPD Plate



(point 1 of Fig. 5.1 on RCD Plate  
page 1-57 )



(point 3 of Fig. 5.1 on RPD Plate  
page 1-57 )



(point 2 of Fig. 5.1 on Scale selection  
page 1-57 )



(point 4 of Fig. 5.1 on Totals  
page 1-57 )

- F1+0 General Total
- F1+1 Partial Total
- F1+2 Product Code Total
- F1+3 Client Code Total
- F1+4 Plate Code Total
- F1+5 Customizable fields
- F1+6 Cut printer paper
- F1+7 MPP operation
- F1+8 MPP code
- F1+9 Progressive number

- F2+0 Reprint
- F2+1 Range
- F2+2 Set Point
- F2+3 Display range
- F2+4 Coefficient
- F2+5 Memory status
- F2+6 Contrast
- F2+7 Display
- F2+8 Date Time
- F2+9 Field1

### 5.3.8 Double weighing functions: without RCD or RPD with manual entry of first weight



(point 1 of Fig. 5.1 on Customizable fields  
page 1-57 )



(point 3 of Fig. 5.1 on Date Time  
page 1-57 )



(point 2 of Fig. 5.1 on Scale selection  
page 1-57 )



(point 4 of Fig. 5.1 on Totals  
page 1-57 )

- F1+0 General Total
- F1+1 Partial Total
- F1+2 Product Code Total
- F1+3 Client Code Total
- F1+4 Plate Code Total
- F1+5 Contrast
- F1+6 Cut printer paper
- F1+7 MPP operation
- F1+8 MPP code
- F1+9 Progressive number

- F2+0 Reprint
- F2+1 Range
- F2+2 Set Point
- F2+3 Display range
- F2+4 Coefficient
- F2+5 Memory status
- F2+6 Display
- F2+7 Field1
- F2+8 Field2
- F2+9 Field3

### 5.3.9 Double weighing functions: only RCD or RCD Plate



(point 1 of Fig. 5.1 on RCD Plate  
page 1-57 )



(point 3 of Fig. 5.1 on RCD  
page 1-57 )



(point 2 of Fig. 5.1 on Scale selection  
page 1-57 )



(point 4 of Fig. 5.1 on Totals  
page 1-57 )

- F1+0 General Total
- F1+1 Partial Total
- F1+2 Product Code Total
- F1+3 Client Code Total
- F1+4 Plate Code Total
- F1+5 Date Time
- F1+6 Cut printer paper
- F1+7 MPP operation
- F1+8 MPP code
- F1+9 Progressive number

- F2+0 Reprint
- F2+1 Range
- F2+2 Set Point
- F2+3 Display range
- F2+4 Coefficient
- F2+5 Memory status
- F2+6 Display
- F2+7 Contrast
- F2+8 Customizable fields
- F2+9 Field1

### 5.3.10 Double weighing functions: RPD or RPD Plate



(point 1 of Fig. 5.1 on RPD Plate  
page 1-57 )



(point 3 of Fig. 5.1 on RPD  
page 1-57 )



(point 2 of Fig. 5.1 on Scale selection  
page 1-57 )



(point 4 of Fig. 5.1 on Totals  
page 1-57 )

- F1+0 General Total
- F1+1 Partial Total
- F1+2 Product Code Total
- F1+3 Client Code Total
- F1+4 Plate Code Total
- F1+5 RPD Total
- F1+6 Cut printer paper
- F1+7 MPP operation
- F1+8 MPP code
- F1+9 Progressive number

- F2+0 Reprint
- F2+1 Range
- F2+2 Set Point
- F2+3 Display range
- F2+4 Coefficient
- F2+5 Memory status
- F2+6 Display
- F2+7 Contrast
- F2+8 Date Time
- F2+9 Customizable fields





## 5.4 Description of the functions



### 5.4.1 Lists: use





Paragraphs 5.4.1 on page 1-63 ... 5.4.5 on page 1-65 display the "browsing" modes and how to edit the lists or tables in the terminal.

---

The arrow keys , , ,  allow the operator to "browse" through the tables.

Prolonged pressure on keys ,  allows you to quickly move amongst the various columns of a record while prolonged pressure on

keys ,  accesses the "PAGE UP" and "PAGE DOWN" functions.

When a "cell" in the table is highlighted, the name of the highlighted column is moved to a line at the bottom of the display along with the value in the cell.

### 5.4.2 Lists: code recall

The required list can be accessed by scrolling the menu, from the work page (if the list required is in the work page) or by pressing the corresponding shortcut key (if available).

Digitize the code; during the setting phase, the cursor will move to the code nearest to the one being selected.

Once the setting phase has terminated, you must press the  key again to process the entered code, otherwise you can quit the list without processing the digitized code by pressing `ESC`.

### 5.4.3 Lists: item insertion

The required list can be accessed by scrolling through the menu, from the work page (if the required list is in the work page) or by pressing the corresponding shortcut key (if available).

Press key .

The name of the highlighted column, a symbol → (attesting to the insertion operation) and the characters being digitized, will appear in the bottom line.

Press key  again to return to the list scrolling mode.

Enter the code and press  (this will become the "code" that allows you to univocally identify the list record).

If necessary, you can also load the associated fields by moving to the required column with the arrows, digitizing the required values and

pressing .

Once the parameter setting phase has terminated, press  again to process the newly entered code. You can also enter a new record by moving to the first column or quit the list without processing the digitized code by pressing `ESC`.

#### 5.4.4 Lists: print-out

The required list can be accessed by scrolling through the menu, from the work page (if the required list is in the work page) or by pressing the corresponding shortcut key (if available).

Press the print key .

Press key:

- ✓ SELECT key to print out the selected code
- ✓ ALL to print out the entire table
- ✓ INTERV to print out a section of the table. In this case, enter the first and last code that define the section after having pressed the key.

#### 5.4.5 Lists: code deletion

The required list can be accessed by scrolling through the menu, from the work page (if the required list is in the work page) or by pressing the corresponding shortcut key (if available).

Press key .

Press key:

- ✓ SELECT to delete the selected code
- ✓ ALL to cancel the entire table
- ✓ INTERV to cancel a section of the table. In this case, enter the first and last code that define the section after having pressed the key.

### 5.4.6 Scale selection (available in terminals with more than one scale)

Allows the operator to select the scale to use for the weighing operations from amongst those connected to the terminal. Once selected, the zero setting, tare entry, tare acquisition, print-out, I/O management and transmission functions will refer to the scale in question.

In terminals enabled to operate with several "combined" scales, scale selection also allows the operator to obtain the sum of the weights from more than one weighing platform.

To change the scale selected, press `SELSCL` or follow pathway `...>MENU>Scale selected` and move to the required scale.

### 5.4.7 Adjusting the contrast

To adjust the contrast of the display, follow the pathway:

`...>MENU>Contrast`

(Shortcut key `CONTR`)

Press `+` or `-` to adjust the contrast. Press key `INVER` to change the background colour. To save the new setting in the memory press `SAVE`.

### 5.4.8 Lighting

Select `Always` for permanently enabled backlighting, otherwise select `timed` and the backlighting will switch off automatically 10 minutes after the terminal has failed to detect weight variations or keys pressed. Just press any key or make a weight variation to turn on the backlighting again.

### 5.4.9 Changing the date and time

Follow the pathway:

...>MENU>Date Time

(Shortcut key `DATIME`)

To change quickly from summer to winter time, press `+` or `-` 1 hour, alternatively use the option `CHANGE`.

### 5.4.10 Weight display (only available in single weighing mode)

You can change the way the weight value is displayed on the terminal. The current weight display mode will depend on the type of operating mode set during installation.

To select the display mode follow the pathway:

...>MENU>Display

(Shortcut key `VISUAL`)

The available display modes are:

✓ 12 mm digits

The display shows the gross weight (or net), the weighing symbols and any possible accessory data (codes, etc.).

✓ Selection

In addition to the weight and the usual weighing symbols, the display

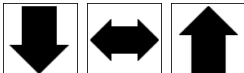
shows one of the following symbols .

To select the range, press `DRANGE`.

The displayed range described here is independent from the range associated with the outputs.

✓ Display tare

In addition to the usual weighing symbols, the terminal can also simultaneously display the net weight and the tare (if entered).

The following indications are displayed:

- ✓ If the tare has been entered by pressing  and multiple tares were not set during installation:

Tare: tare value + unit of measurement

Indications **NET** and **NET** will also be illuminated.

- ✓ If the tare was acquired by pressing  and multiple tares have not been set:

Tare: tare value + unit of measurement

Indications **NET** and T will be illuminated.

- ✓ If the rate is preset ( par. 5.4.27 on page 1-75 and multiple tares have not been set:

Tare C: preset tare value + unit of measurement

Indications **NET** and PT will be illuminated.

NOTE: the indication Tare C means that the tare displayed is a "coded" tare to which a numeric code has been assigned ( par. 5.4.27 on page 1-75 ).

✓ If multiple rates were set during installation:

Tare T: acquired tare value + unit of measurement

Tare 1 PT: preset tare 1 value + unit of measurement

Tare 2 PT: preset tare 2 value + unit of measurement

Or

Tare C PT: preset tare value + unit of measurement

Tare 1 PT: preset tare 1 value + unit of measurement

Tare 2 PT: preset tare 2 value + unit of measurement

Or

Tare PT: "non coded" tare value + unit of measurement

Tare 1 PT: preset tare 1 value + unit of measurement

Tare 2 PT: preset tare 2 value + unit of measurement

Indications **NET** and PT will be illuminated.

NOTE: Tare 1 and Tare 2 may also be recalled via numeric code ( par. 5.4.27 on page 1-75 ).

### 5.4.11 Memory status

If there is insufficient vacant memory, memory can be recovered by following the pathway:

...>MENU>Memory status

---

 **CAUTION** 

---

The memory recovery operation may require a few minutes during which time the terminal cannot be used. Do not switch off the terminal during this operation as this could result in loss of the data in the memory.

---

### 5.4.12 Reprint

See par. 5.5.1 on page 1-82 .

### 5.4.13 Diagnostics A - Diagnostics B (only for terminals connected to digital load cells)

Diagnostics A refers to scale A.

Diagnostics B refers to scale B (if installed).

This user menu item is only available when there are digital cell errors ( par. 10.2 on page 1-126 ). It allows you to identify what caused the error. Follow this path:

...>MENU>Diagnostics

If the instrument is not subject to calibration checks, CONT can be pressed to display the measured weight despite the error.

Remember that this can only be done in the case of serial number errors or ones due to non-configured digital cells.

The error message will reappear when the terminal is powered again unless the cause of error is eliminated.

#### 5.4.14 Setting the outputs as Set-points (if enabled)

The two available outputs may be used in setpoint mode. In this way, the output is activated when the weight reaches the set value.

...>MENU>Data management>Set Point

(Shortcut key SETPNT)

#### 5.4.15 Setting the outputs as Ranges (if enabled)

The two available outputs may be used in Range mode. The output is activated when the weight is within the set range. To set the range, follow pathway:

...>MENU>Data management>Range

(Shortcut key RANGE)

#### 5.4.16 Product code

Allows the product codes table to be accessed for entries or recalls. The product code is a numeric code with a maximum 6 digits or an alphanumerical code of 10 characters, while the alphanumerical description that can be associated with the code may be up to 20 characters long. To enter a product code, follow the pathway:

...>MENU>Data management>Code management>Product code list

(Shortcut key PROCOD)

#### 5.4.17 Client code

Allows the client codes tables to be accessed for entries or recalls. The client code is a numeric code with 4 digits or an alphanumeric code with 10 characters, while the alphanumeric description that can be associated with the code may be up to 20 characters long. To enter a client code, follow the pathway:

```
...>MENU>Data management>Code management>Client code  
list
```

(Shortcut key CLIENT)

#### 5.4.18 Generic code (only available in single weighing mode)

Allows the generic codes tables to be accessed for entries or recalls. The generic code is a numeric code with 4 digits or an alphanumeric code of 10 characters, while the alphanumeric description that can be associated with the code may be up to 20 characters long. To enter a generic code, follow the pathway:

```
...>MENU>Data management>Code management>Generic code  
list
```

(Shortcut key GCCOD)

#### 5.4.19 Plate (only available in double weighing mode)

Allows access to the plate codes tables for entries or recalls. The plate code is an alphanumeric code of 10 characters, while the alphanumeric description that can be associated with the code may be up to 20 characters long. To enter a plate code, follow the pathway:

```
...>MENU>Data management>Code management>Plate code  
list
```

(Shortcut key PLATE)

### 5.4.20 Coefficient code

Allows you to enter a number that will be multiplied (or divided) by the weight value. This function can be of use when the unit of measurement needs to be converted. For example, you can calculate the number of litres if the specific weight and overall weight of a liquid are known.

Follow this path to handle the coefficient:

...>MENU>Data management>Coefficient management

(Shortcut key COEF)

On accessing the page, proceed by pressing  to access the coefficients table where the value of the required coefficient can be entered. After this, select the required type of operation (multiplication "\*" or division "/") and the rounding value for the result. This latter is just a numeric value without unit of measurement.

Each group of data can be recalled by means of a numeric code with 4 digits or an alphanumerical code with 10 characters.

### 5.4.21 Data recall (only available in double weighing mode)

See par. 7.1.1 on page 1-88 .

### 5.4.22 Plate recall (only available in double weighing mode)

See par. 7.1.4 on page 1-93 .

#### 5.4.23 Preset plate recall (only available in double weighing mode)

See par. 7.2.2 on page 1-96 .

#### 5.4.24 Preset weight recall (only available in double weighing mode)

See par. 7.2.2 on page 1-96 .

#### 5.4.25 TCA codes (only available in single weighing mode)

An archive called TCA can be formed in order to load various data items into the terminal memory at the same time, but in a single setting.

The codes of the Product, Client, Generic and Coefficient archives can be recalled and activated (if used) and the tare value can also be loaded (or tares, in the case of multiple tares). The code used to save/recall this archive can either be a numeric one with 4 digits or an alphanumerical one with 10 characters. An alphanumerical description with up to 20 characters can also be associated with the record of the TCA archive.

Follow this path to access the TCA menu:

```
...>MENU>Data management>Tca code list
```

(Shortcut key TCA)

#### 5.4.26 Display range (only available in single weighing mode)

Allows the operator to set the range values which, once reached, change the status of the indications on the display.

These values are independent from the ones set the the outputs (if any) and do not activate these latter.

These values can only be set if the `Seletion` display mode is selected. Follow the pathway:

```
...>MENU>Data management>Display range
```

(Shoftcut key `DRANGE`)

#### 5.4.27 Preset tares (only available in the single weighing mode)

In the addition to management of tares acquired from the weight on the scale and tares entered via the keypad, the terminal also manages an archive of preset tares containing a number of values defined during the installation phase. Each value can be recalled by way of a numeric code of 4 digits. Once they have been recalled by entering the relative code, preset tares are automatically subtracted from the weight on the scale. Preset tare codes may be entered by following the pathway:

```
...>MENU>Data management>Preset tare
```

(Shortcut keys `TAREC1` to recall the `Preset tare 1 list` and `TAREC2` to recall the `Preset tare 2 list`).

Functions `Preset tare 1 list` and `Preset tare 2 list` allow you to recall a tare memorized in the multiple tare register by digitizing the relative code. These functions are only available if the terminal has been enabled to operate with multiple tares during the installation phase. The tare 2 value can be multiplied by a number, designated `Packs number`, which may be entered via the keypad to obtain a tare sum value (e.g. the sum of the tares of n containers of the same weight). The result is subtracted from the gross weight. Press shortcut key `PACKSN` to enter the number of packs. Functions `Preset tare 1 list` and `Preset tare 2 list`, together with the `Packs Number`, allow products with both primary (e.g. pallets) and secondary (e.g. boxes) packaging to be weighed.

#### 5.4.28 Progressive number

The terminal handles a 6-digit progressive number used to count the number of weighing operations performed: this value starts from 1 and is automatically increased by one unit after each print and/or weighing operation (it therefore indicates the value of the next print or weighing operation).

To change the progressive number, follow the pathway:

```
...>MENU>Data management>Progressive
```

(Shortcut key `PROG.N`)

If the progressive number = 0 (zero), it will neither be increased nor printed.

### 5.4.29 Modifiable archives

The terminal can inhibit accidental modification or deletion of archive records by setting to NO.

If NO is to be switched to YES, a numeric password must be entered in the Setup phase.

### 5.4.30 Totals management

The terminal provides functions for totalizing the weighing data associated with the various codes. The totalizing operation involves adding the current weight value to the sum of the previous weights and increasing the number of weighing operations by one. To access the list of available Totals, follow the pathway:

```
...>MENU>Totals management
```

(Shortcut key TOTALS)

#### ✓ General totals

These totalizing functions provide general totals for the gross weight (in single weighing mode), net weight, tare (in single weighing mode) and the number of weighing operations regardless of any codes associated. The data can be obtained using the following functions:

```
...>MENU>Totals management>General total
```

(Shortcut key GENTOT)

```
...>MENU>Totals management>Partial total
```

(Shortcut key PARTOT)

A print can be obtained for each total by pressing the  key or by zero setting with RESET.

## ✓ Totals by code

Saves the gross weight, tare, net weight, the result and number of weighing operations associated with: product code, generic code (single weighing mode only), client code, TCA code (single weighing mode only), plate code (double weighing mode only) and RPD code (double weighing mode only). The data can be accessed through the following functions:

...>MENU>Totals management>Product code total  
(Shortcut key PROTOT)

...>MENU>Totals management>Generic code total  
(Shortcut key GCTOT)





...>MENU>Totals management>Client code total  
(Shortcut key CLTOT)

...>MENU>Totals management>TCA code total  
(Shortcut key ACTTOT)

...>MENU>Totals management>Plate total  
(Shortcut key PLATET)

...>MENU>Totals management>RPD total  
(Shortcut key RPD.T)

Once the totals menu has been selected, you can:

- ✓ print out the total of a single code by pressing  followed by `SELECT`. At the end of the printing phase, the printed totals can be reset by responding `YES` to the query;
- ✓ print out the entire totals table for that type of code by pressing  followed by `ALL`. At the end of the printing phase, the printed totals can be reset by responding `YES` to the query;
- ✓ print out the totals of a given range of codes by pressing  followed by `INTERV`.
- ✓ Reset the totals by pressing .
 

Press key:

  - ✓ `SELECT` to delete the selected code
  - ✓ `ALL` to delete the entire table
  - ✓ `INTERV` to delete a section of a table. In this case, enter the first and last code that define the section in question.
- ✓ `Journal entry total`



In this version, the codes entered and the net (net weight), gross, tare, number of weighing operations, date (day and month) and time (hours and minutes) are saved for each weighing operation (second weight in the case of double weighing mode).

This saves the "history" of the weighing operations after which the totals can be extracted in advanced search mode (e.g. the net weight transported by carrier X to consignee Y provided by supplier Z can be found).

The decision to totalize in this type of mode limits the overall capacity of codes that can be memorized owing to the larger amount of memory that this operation requires, using 30 generic codes, 30 product codes and 30 carrier codes. About 3000 weighing operations (sufficient to cover 300 weighing operations per day for 10 days) can be saved with the standard memory. The conventional totals, i.e. partial, general and per single code, are obviously still available.

To access the totals in journal entry mode, the search rules must be created in order to define how the data are to be summed.

The procedure is as follows:

- ✓ access ...>MENU>Totals management or press the shortcut key TOTALS;
- ✓ press DBASE;
- ✓ use the arrows to select the items corresponding to the required codes;
- ✓ enter the code number and confirm with ;
- ✓ press ESC;
- ✓ the data will appear on the display. Press  if you need a print-out.

An example of a configuration page is given below.

Configure a search for:

- Client code: 10
- Product code:
- Carrier code:

The totals mask per client code in the journal entry format will be:

Client C.	Product C.	Generic C.	Gross	Tare	Net	Weighing N.
10	1	100230	540	25	515	1
10	1	2548	620	25	595	1
10	3	3684	580	20	560	1
10	4	565464	470	15	455	1

- ✓ Weight sum report (only available in the weight sum function of the single weighing mode)  
See par. 6.2 on page 1-84 .

#### 5.4.31 Display MPP data item

See par. 8.7 on page 1-116 .

#### 5.4.32 MPP operation

See par. 8.7 on page 1-116 .

#### 5.4.33 Customizable fields

Allows access to 7 fields that can be customized by the user and within which texts can be entered. They can also be printed. The description of the functions occurs during the installation phase of the terminal when the operator can enter associated numerical texts 22 characters in length.

The functions are accessed by following the pathway:

```
...>MENU>Fields
```

(Shortcut key `FIELDS`)

#### 5.4.34 Cut paper function

This allows the cutter on the printer to be managed if a printer of the STB112 type is used with "NO" paper cutting mode.

```
...>MENU>Cut printer paper
```

(Shortcut key `CUT`)

#### 5.4.35 Timed high resolution mode

Allows the weights of the scales to be displayed for 4 seconds in high resolution mode, i.e. in tenths of a division.

```
...>MENU>High resolution
```

(Shortcut key `HIRES`)

## 5.5 Printing weighing data

The printer is normally connected to the terminal by way of the COM1 serial port ( par. 8.9 on page 1-121 ).

Print-outs are obtained by pressing . Printing is performed if:

- ✓ the weight is valid, i.e. not less than zero and not more than the maximum scale capacity;
- ✓ the weight is stable;
- ✓ the printer is connected, powered, there are no other print jobs currently in progress and there is paper in the printer.

The data printed are specified each time in the manual. If the relative function is enabled, the product code and net weight may be printed in the form of a bar code.

The print-out can be customized using a PC and a specific program: contact your dealer for further information.

Consult the instruction manual of your printer for details regarding printing characteristics, paper format, printer maintenance, etc.

### 5.5.1 Weighing data reprint

Allows the last weighing operation carried out to be reprinted without changing the progressive number or any totals that may have been calculated.

The original print can only be distinguished from the reprint if the terminal is operating in calibrated mode. In this case, the word Reprint will appear on the latter version.

To obtain a reprint, follow the pathway:

```
...>MENU>Reprint
```

(Shortcut key REPRIN)

## 6. SINGLE WEIGHING MODE

The terminal operates in "single weighing" mode when all the weight data (gross, net and tare) appear on a single print. Single weighing mode can be characterized by the following operating modes: Standard, sum weighing, loading and unloading extraction.

### 6.1 Standard operation

In standard operating mode, the terminal can acquire the gross (or net) weight on the scale and display it along with the weighing symbols. It can also print the value if the printer is installed.

In this case, the available display formats are *Standard* and *Selection* (see par. 5.4.10 on page 1-67 ).

The printed data are:

- ✓ date and time
- ✓ progressive number
- ✓ product code (if entered)
- ✓ client code (if entered)
- ✓ generic code (if entered)
- ✓ Gross (if required)
- ✓ Tare (if entered)
- ✓ Net

To print, press , and make sure that:

- ✓ the weight is stable;
- ✓ the weight value is not negative or overloaded.

## 6.2 Sum weighing operation

The sum weighing operating mode allows you to perform several weighing operations in sequence without unloading the scale, zero setting the net weight after each operation. To move from one weighing

operation to the next, press  when the weight is stable.

On completion of this operation:

- ✓ the net weight is zero-set and the weight currently on the scale is taken as the tare;
- ✓ a string is sent to the serial port or the data are printed (if a printer is connected).

On termination of the weighing operations, obtain the total weight and return to the gross weight by pressing `REPORT`.

The display formats available in this operating mode are `Standard` and `Selection` (see par. 5.4.10 on page 1-67 ).

## 6.3 Loading extraction operation

When selected and associated with the I/O devices, this operating mode allows you to perform simple dosing operations with a number of different components.

The I/O are selected during the installation phase.

Comply with the instructions in par. 5.4.14 on page 1-71 and enter the Set Point 01 and Set Point 02 values. Set Point 01 defines the final weight value to extract, Set Point 02 gives the weight value that, subtracted from the Set Point 01 value, marks the change from fast extraction mode to slow extraction mode.

Press the key corresponding to the `START` indication to zero-set the extracted weight and enable scale loading. The display shows the gross weight (the weight on the scale) and the extracted weight (the weight gradually loaded on to the scale). The extraction operation can be concluded by pressing `STOP`.

The display format used is the `Extraction` type (see par. 5.4.10 on page 1-67 ).

Press button  to print-out the following weighing data:

- ✓ date and time
- ✓ progressive number
- ✓ product code (if entered)
- ✓ client code (if entered)
- ✓ generic code (if entered)
- ✓ Gross
- ✓ Extracted

#### 6.4 Unloading extraction operation

This operating mode is identical to the previous mode expect that in this case, you start with a loaded scale and gradually remove material.

Enter the Set Point 01 and Set Point 02 values ( par. 5.4.14 on page 1-71).

Press the key corresponding to the *START* indication to zero-set the extracted weight and enable scale unloading. The display will show the gross weight (the weight on the scale) and the extracted weight (the weight unloaded from the scale). The extraction operation can be concluded by pressing *STOP*.

Press key  to print out the following weighing data:

- ✓ date and time
- ✓ progressive number
- ✓ product code (if entered)
- ✓ client code (if entered)
- ✓ generic code (if entered)
- ✓ Gross
- ✓ Extracted



## 7. DOUBLE WEIGHING MODE

DOUBLE WEIGHING options are most commonly used for weighing means of transport, which are weighed prior to loading and then again after loading, to determine the quantity of goods that are being transported.

Double weighing options can be carried out with:

- ✓ entry-exit operations;
- ✓ preset weight operations.

Entry-exit operations can be carried out with:

- ✓ data recall (4 numbers) which are automatically assigned for entry-exit operations (abbreviated with RCD in this text);
- ✓ data recall with a vehicle licence plate (10 characters) for entry-exit operations where the licence plate is entered before each weighing operation (RCD Plate);
- ✓ without data recall codes for entry-exit operations, where the entry weight is entered before each exit weighing operation.

Preset weight operations can be carried out with:

- ✓ data recall (4 numbers) for preset weight operations (RPD);
- ✓ data recall with a vehicle licence plate (10 characters) for preset weight operations (RPD Plate).

## 7.1 Entry-Exit functions

Entry-Exit functions require two weighing operations:

- ✓ an entry weighing operation when the weight of the means of transport is taken as first weight and, together with auxiliary data (product code, client code, vehicle licence plate and coefficient), is given a recognition code;
- ✓ an exit weighing operation when, having retrieved the first weight and any auxiliary data using the recognition code, the weight of the vehicle is recorded as the second weight and then the difference between the two is calculated (to give the net weight).

The recognition code used during these procedures can be a data recall code (RCD with 4 figures) or a vehicle licence plate code (RCD Plate with 10 characters).

The two types of code are for two different methods of carrying out entry weighing.

### 7.1.1 Entry operations in Entry/exit mode with Data recall

This type of procedure is enabled during the installation phase.

The entry and exit operating phases do not necessarily have to be progressive. The difference between the entry and exit weights can be calculated at the time of the second weighing.

For each entry print-out, the terminal allocates and prints out a code (the RCD code). If this is entered before the second weighing, the data from the first weighing (weight, product code, client code, vehicle licence plate, coefficient, date, time and progressive number) are recalled.

To obtain a print-out of the entry weight, or first weight:

- ✓ enter the required auxiliary data: product code, client code, licence plate of the vehicle and coefficient (if such data need to be recorded);
- ✓ make sure that the printer is connected, powered and that it contains paper;
- ✓ press key  to print out the first weight.

Printing will only take place if:

- ✓ the weight stabilizes within 10 seconds;
- ✓ the weight is not negative or over the maximum weight capacity.

The data printed out are:

- ✓ date
- ✓ time
- ✓ a progressive number
- ✓ product code with details (if entered)
- ✓ client code with details (if entered)
- ✓ licence plate with details (if entered)
- ✓ RCD code
- ✓ first weight
- ✓ any texts that may have been entered (see par. 5.4.33 on page 1-81 )

The data relating to the first weighing operation are retained in the memory until the second weight is printed out. After this, the data are cancelled together with the data recall code.

The RCD archive can hold up to 300 elements (the number of elements can be modified during the installation phase).

If the terminal has memorised almost the maximum number of RCD codes, a message will appear asking for the archive to be resized.

### 7.1.2 Exit operations in entry/exit mode with Data Recall

The terminal is only able to print out the second weight after the operator has recalled the RCD code of the first weight. Proceed in the following way:

- ✓ Press `RCD`.
- ✓ Enter the RCD code after having read it on the print-out of the entry weighing operation.

If the code shown is the one required, merely confirm it by pressing



The product code, client code and vehicle licence plate will be displayed along with their relative details registered during the entry operation. The operator can modify these by entering the desired information or by accessing the relative list. Each setting must be confirmed by pressing



Press key  to start the exit operation.

To cancel the operation, press  in the work window.

Remember that once the RCD code has been recalled, you can also modify the product code, the client code and the licence plate by using the `PROCOD`, `CLIENT` and `PLATE` keys. These changes will only appear on the print-out of the second weight and do not change the data associated with the first weight.

Printing will only take place if:

- ✓ the weight stabilizes within 10 seconds;
- ✓ the weight is not negative or over the maximum weight capacity.



The data printed depend on the printer connected or the configuration chosen for the first weighing.

- ✓ If you print on a multicopy card printer, the printed data will be: date, time, progressive number, product code with relative details, client code with relative details, licence plate with relative details, RCD code, first weight, second weight, net weight, coefficient and result (if enabled).
- ✓ If you print on a continuous sheet printer, the printed data will contain all the information given for first weighing plus: date, time, progressive number, product code with relative details, client code with relative details, licence plate with relative details, RCD code, first weight, second weight, net weight, coefficient and result (if enabled).

If the weighing operation terminates correctly, the requested totals are added up, the next progressive number is used and the RCD code and its relative data are cancelled.

### 7.1.3 Unused RCD code recovery





The following procedure enables the entry operations again when second weighing procedures cannot be accomplished:

- ✓ access the list of RCD codes using the path below  
...>MENU>Data management>Code management>RCD list  
(Shortcut key RCD)
- ✓ check how many RCD codes the archive contains. Remember that the archive contains RCD codes for which only the entry weighing procedure has been carried out.
- ✓ to print out the list of RCD codes and their relative details, press  followed by ALL to print out the entire list, SELECT to print out a single code, INTERV to print out a section of the list. In this last case, you must enter the beginning and end of the section required.
- ✓ To cancel or zero any unused RCD codes when it will be impossible to take any future readings, press  followed by ALL to zero the entire list, SELECT to cancel a single code, INTERV to cancel a section of the list. In this last case, you will also need to enter the beginning and end of the section.

### 7.1.4 Entry/Exit operations with Licence Plate Data Recall

The RCD Plate code consists of a maximum of 10 alphanumerical characters which the operator enters manually and which must be set before each entry weighing operation. A description 20 characters long can be associated with the Plate code.

Proceed in the following way:

- ✓ Access the list of RCD Plate codes following the pathway  
...>MENU>Data management>Code management>RCD Plate list  
(Shortcut key RCDPLT)
- ✓ Press key  to enable entries in the list (see par. 5.4.1 on page 1-63).
- ✓ Enter the licence plate (max. 10 characters) and confirm it with . If the licence plate list already contains the entered licence plate (pathway ...>MENU>Data management>Code management>Plate code list or shortcut key PLATE), the associated description will be automatically displayed.
- ✓ Move to the description field with the  key. If the description already exists, it can be modified without altering the one already memorized with the same licence plate number in the Plate Code List. If there is no such description, a new description value can be entered without leading to a setting in the Plate Code List.
- ✓ If a description value is entered, confirm it by pressing .
- ✓ Press  to quit the RCD Plate List and confirm use of the licence plate for the weighing operation.

Refer to par. 7.1 on page 1-88 for the entry/exit procedure. In this case, the reference key is not RCD but RCDPLT.

Unlike RCD mode, the printed data are:

- ✓ date
- ✓ time
- ✓ progressive number
- ✓ product code with relative details (if entered)
- ✓ client code with relative details (if entered)
- ✓ RCD Plate with relative details
- ✓ the weight data of the weighing operation in progress
- ✓ any texts that may have been entered (see par. 5.4.33 on page 1-81 )

Remember that in the case of RCD Plate, information about the first weighing is associated with the licence plate of the vehicle on entry.

The card need not be printed in this case, since the first weighing data can be recalled by setting the vehicle licence plate again when the vehicle reaches the exit.

The procedure can be configured in both modes during the installation phase:

- ✓ with data print-out;
- ✓ with data memorizing.

The selected mode will appear on the display when the machine is powered.

---

 **WARNING** 

---

The explanations given in par. 7.1 on page 1-88 about printing, the size of the archive, unused weight recovery and so forth, are also valid for RCD Plate mode. In this case however, the relevant key is RCDPLT and not RCD.

---

## 7.2 Preset weight options

The preset weight options are used when the first weight (or tare) of a vehicle is known and therefore do not need to be weighed.

The preset weights are associated with a code that can be used to recall them.

Besides the preset weight, each code can also store auxiliary information such as the product code, client code, licence plate and coefficient.

Remember that such data can also be entered afterwards on the print-out by using the `PROCOD`, `CLIENT`, `PLATE` and `COEF` keys. In this case however, the information is not memorized together with the code and is valid only for the operation in progress.

The recognition code used during these procedures can be the data recall type with preset weights (RPD with 4 figures or 10 alphanumerical characters) or the plate type (RPD Plate with 10 alphanumerical characters) decided during the installation phase.

### 7.2.1 How to make the list of preset weights

As indicated previously, the preset weights can be associated with an RPD or RPD Plate code.

The list of preset weights is made in the following way.

Carry out the following operations (see par. 5.4.1 on page 1-63):

- ✓ press `RPD` (or `PPLATE`);
- ✓ enter the desired code;
- ✓ enter the weight to be memorized;
- ✓ enter the product code;
- ✓ enter the client code;
- ✓ enter the plate (if it is not RPD Plate);
- ✓ enter the coefficient;
- ✓ repeat the procedure to enter a new code.

### 7.2.2 Weighing procedures with preset weights

Once the vehicle is on the weighing scales, press RPD (or PPLATE) and enter the desired code to recall the first weight preset by the list, the

associated data and then confirm with .

The weight on the scales, the preset weight code and the preset weight will appear on the display.

Press  for a print-out of the weight. The following data will be printed on the print sheet:

- ✓ date and time
- ✓ progressive number
- ✓ product code and details (if entered)
- ✓ client code and details (if entered)
- ✓ licence plate and details (if not RPD Plate)
- ✓ RPD code (or RPD Plate) and relative 1st associated weight
- ✓ 2nd weight
- ✓ net weight
- ✓ coefficient and result (if enabled)
- ✓ any texts that may have been entered (see par. 5.4.33 on page 1-81 )

### 7.3 Options for entering the first weight manually

In the installation phase, you can choose the option that allows the first weight to be entered manually.

This operating mode can be enabled individually. However, it is always enabled with the self-assigned data recall or with the data recall from Plate operating modes.

If enabled singly, the entry operation can also be accomplished otherwise only the exit operation can be carried out.

The entry operation is only printed and the relative data, including the first weight, have to be re-entered manually when the second weighing operation is carried out.

The first weight is entered by moving to the "WEIGHT 1 R." window and digitizing the weight.

Confirm with .

The value of the entered weight must be between 0 and the maximum capacity.

Press  to obtain a print-out of the weight.



## 8. OPTIONS

Optional expansion boards (with the exception of the MPP memory expansion board) are installed in the slots provided on the rear of the terminal (see points 6, 7 and 8 Figure 3.2 on page 1-22 ).

For the positions and numbering of the outputs (I/O, COM, BCD), refer to the label on the bottom of the terminal.



Figure 8.1 - Outputs identification label on base of terminal (citi0410.jpg)

The numbering of the I/O points, the serial ports and the BCD ports is to be considered along with the position of the boards in the slots (see Figure 3.2 on page 1-22 ).

## Inputs

Slot	N <sup>o</sup> Input	designation
CPU board (slot0)	IN 1	INPUT 01
	IN 2	INPUT 02
Slot1	IN 1	INPUT 11
	IN 2	INPUT 12
	IN 3	INPUT 13
	IN 4	INPUT 14
Slot2	IN 1	INPUT 21
	IN 2	INPUT 22
	IN 3	INPUT 23
	IN 4	INPUT 24
Slot3	IN 1	INPUT 31
	IN 2	INPUT 32
	IN 3	INPUT 33
	IN 4	INPUT 34

## Outputs

Slot	N°output	designation
CPU board (slot0)	OUT 1	OUTPUT 01
	OUT 2	OUTPUT 02
Slot1	OUT 1	OUTPUT 11
	OUT 2	OUTPUT 12
	OUT 3	OUTPUT 13
	OUT 4	OUTPUT 14
Slot2	OUT 1	OUTPUT 21
	OUT 2	OUTPUT 22
	OUT 3	OUTPUT 23
	OUT 4	OUTPUT 24
Slot3	OUT 1	OUTPUT 31
	OUT 2	OUTPUT 32
	OUT 3	OUTPUT 33
	OUT 4	OUTPUT 34

## Serial ports

Slot	N°com	designation
CPU board (slot0)	COM 1	COM 01
	COM 2	COM 02
	COM 3	COM 03
Slot1	COM 1	COM 11
	COM 2	COM 12
Slot2	COM 1	COM 21
	COM 2	COM 22
Slot3	COM 1	COM 31
	COM 2	COM 32

## BCD

Slot	designation
Slot1	BCD 1
Slot2	BCD 2
Slot3	BCD 3

8.1 4 I/O board

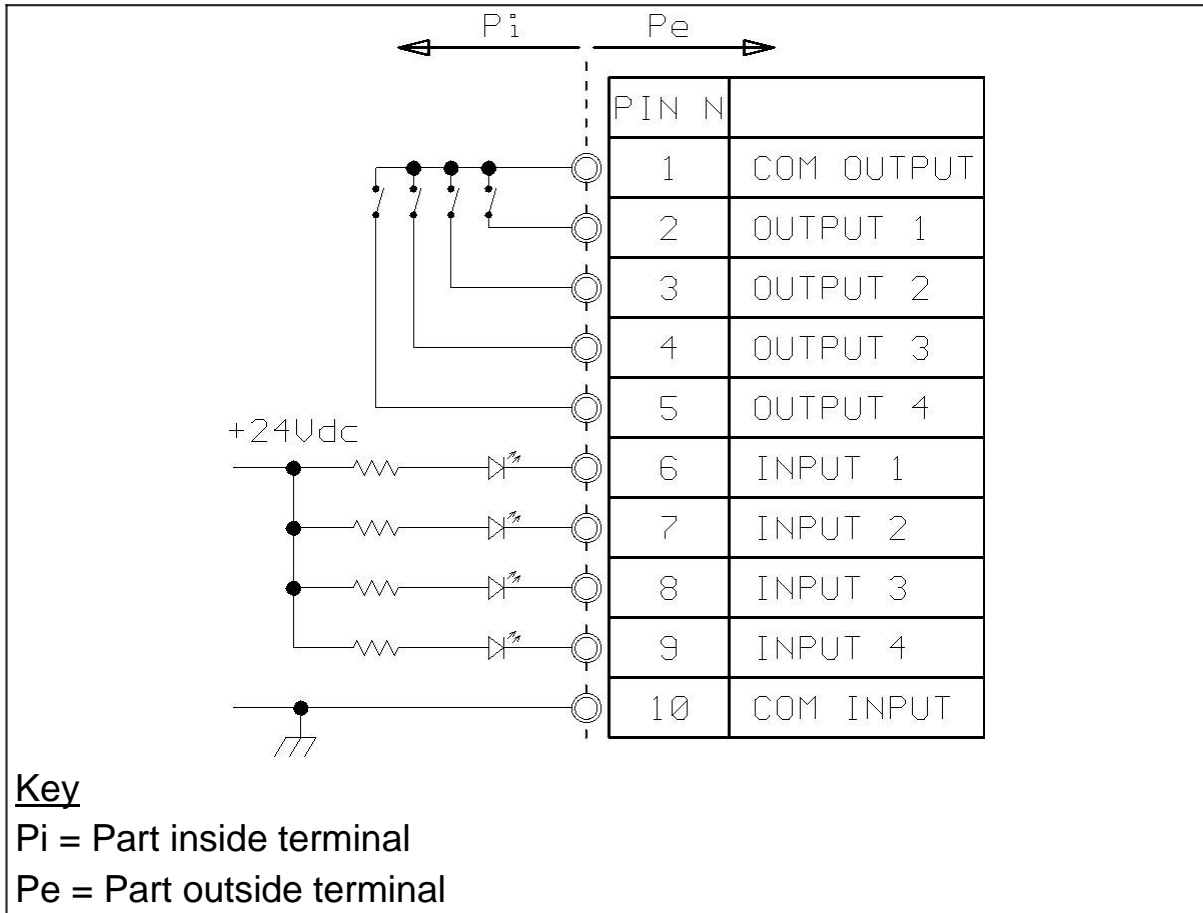

Figure 8.2 - Connection diagram for optional 4 INPUT - 4 OUTPUT board (log0009.gif)

The figure shows the connection terminals of the 4 I/O board.

For specific information on connection refer to par. 3.8 on page 1-32 .

## 8.2 Board with 4in/12out

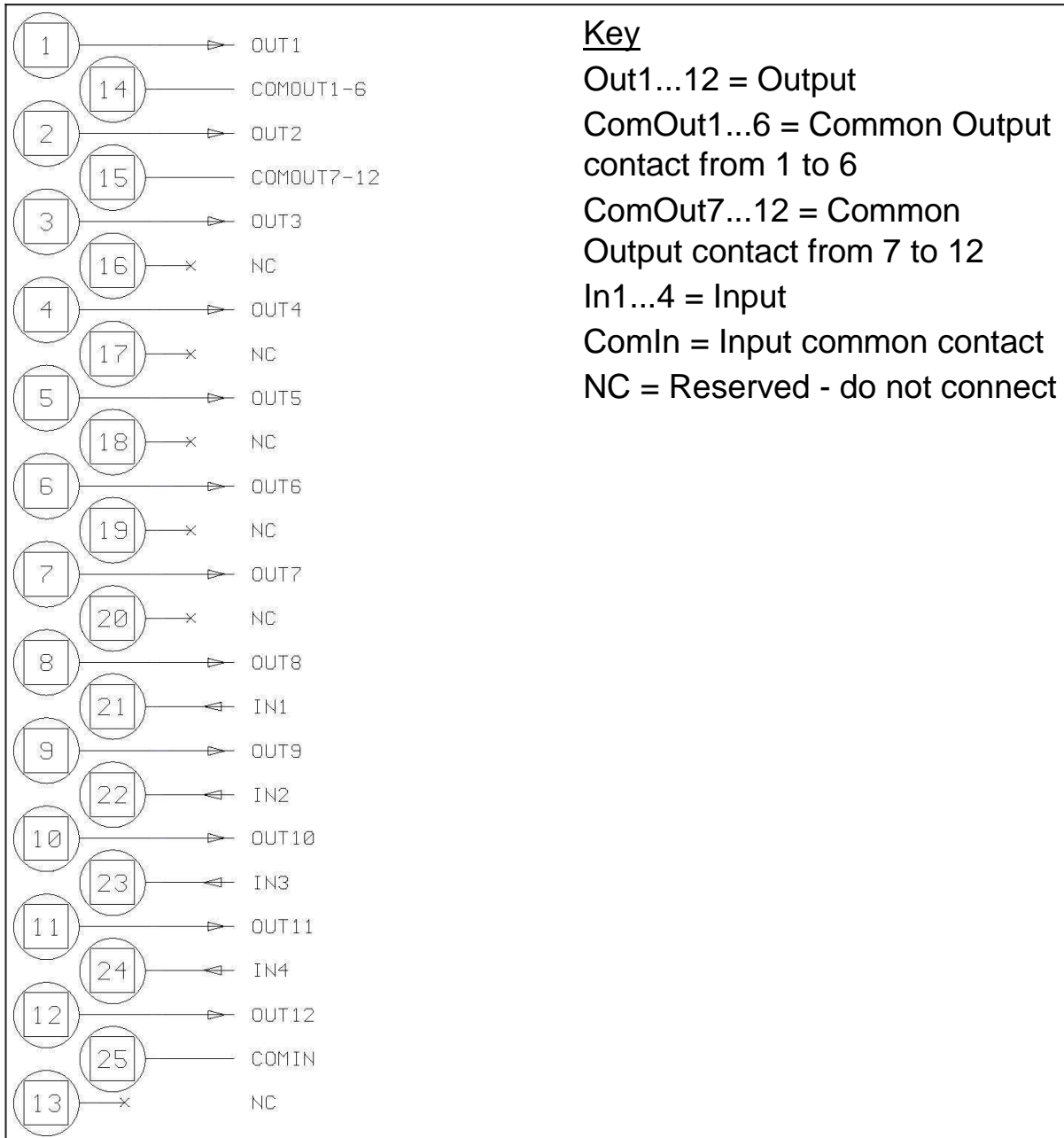

Figure 8.3 - Connection diagram for optional board with 4in/12out (citi0409.gif)

The figure shows the connection terminals of the 4in/12out board.

 CAUTION 

---

Technical specifications:

Input:

Maximum input voltage = 24Vdc

Maximum input current = 5mA

The inputs can be controlled by a mechanical contact or by a transistor of the NPN type (negative common contact)

Output:

Transistor contact (OPTOMOS)

Maximum switchable voltage = 24 Vac/dc

Maximum switchable current = 100 mA

---

### 8.3 BCD parallel 5V

The type of board is identified by a label next to the D-type connector. The 25-pin female connector provides BCD signals of the weight as it displayed on the terminal, i.e. number of divisions multiplied by the value of the division.



Operating limits

$V_{out Max} = +5V$

$I_{out Max} = +/- 10 mA$

---

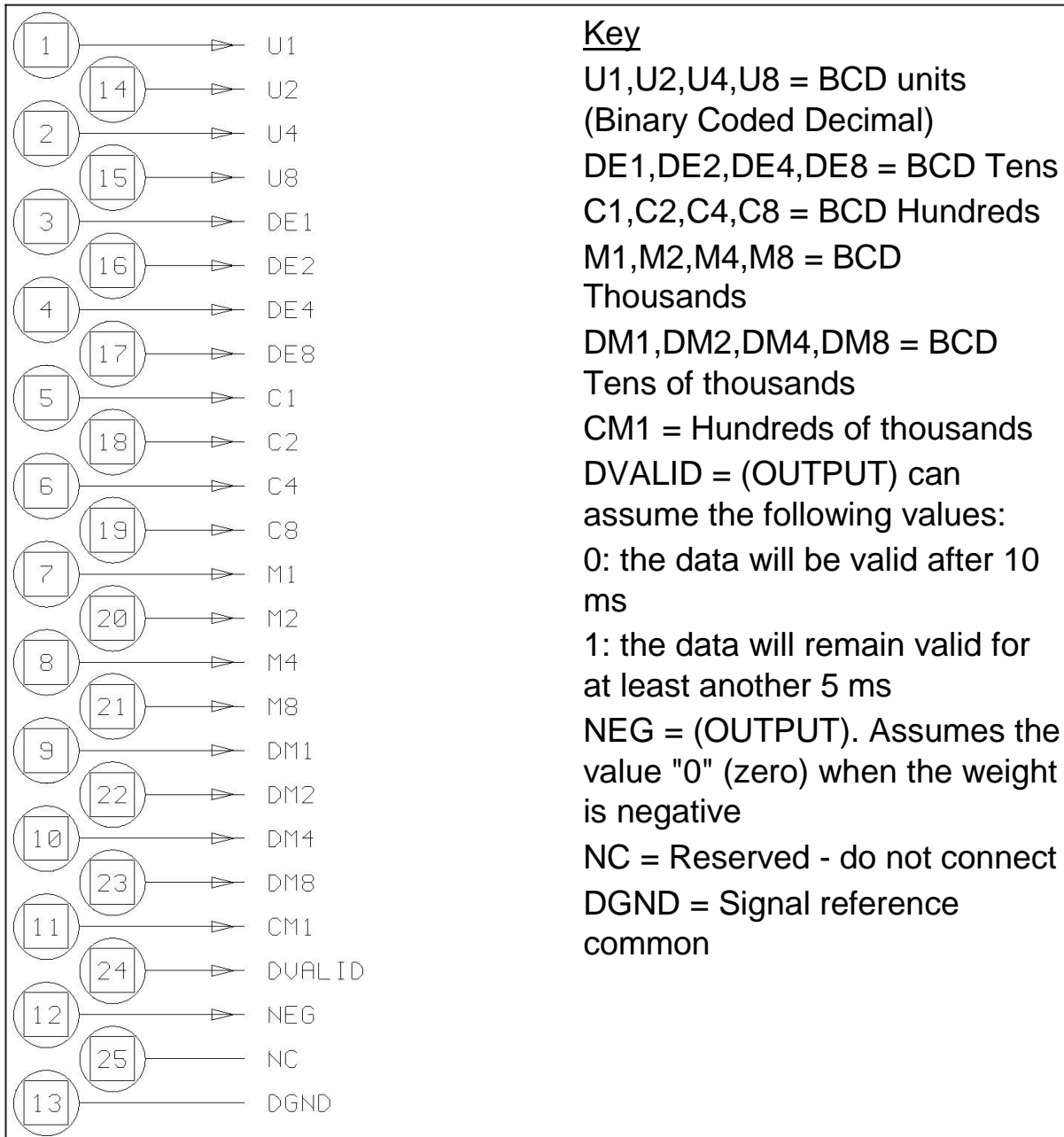

Figure 8.4 - Parallel 5V TTL BCD output connector (log0060.gif)

## 8.4 Calculator BCD

A label next to the connector identifies the type of board.

The 25-pin female connector provides the following BCD signals representing the weight in divisions without taking into account the value of the division.



The operating limits for this type of output are:

$$V_{\text{out Max}} = +5V$$

$$I_{\text{out Max}} = +/- 10 \text{ mA}$$

---

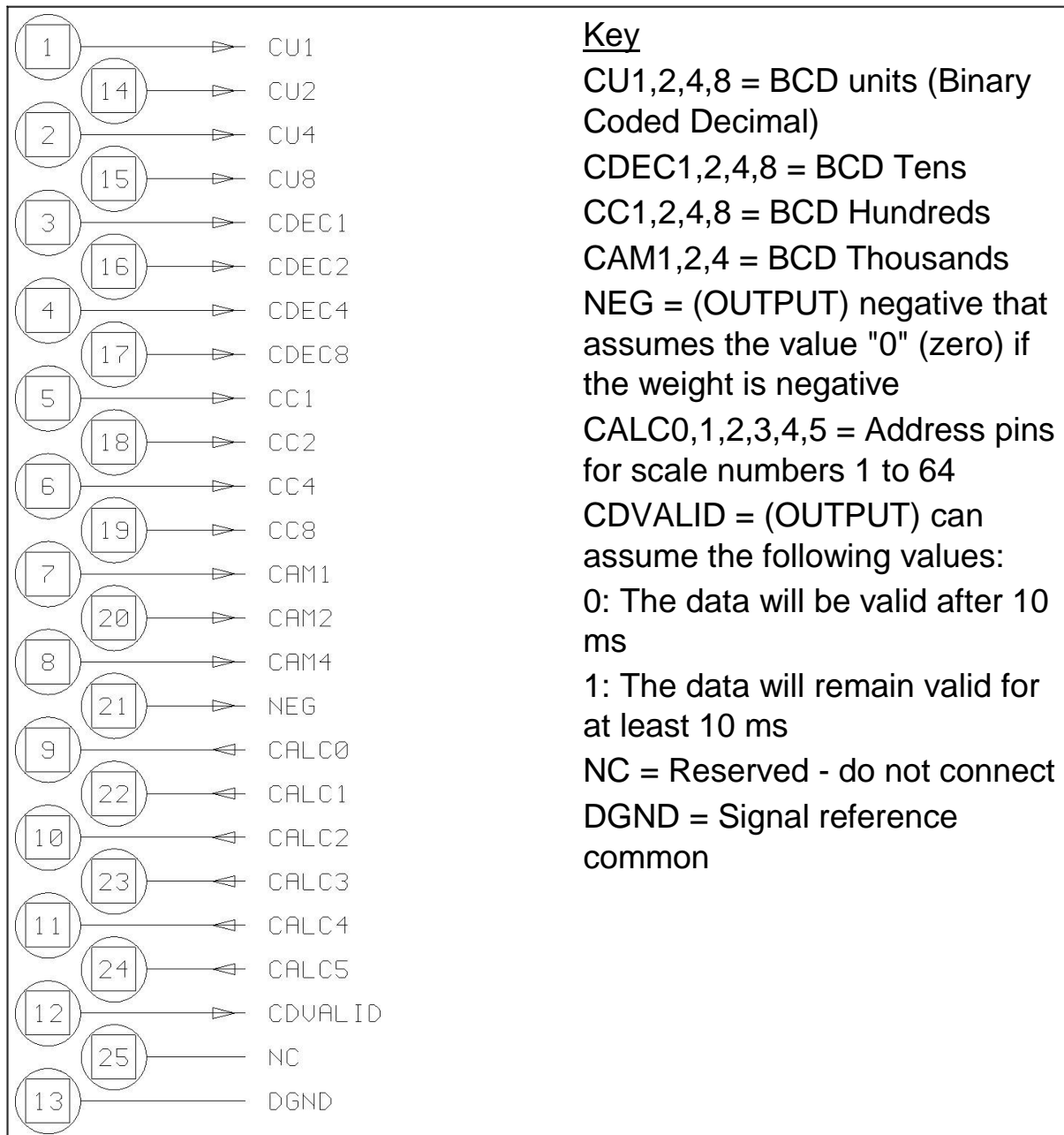

Figure 8.5 - Calculator BCD output connector (log0061.gif)

### 8.5 Parallel 24V source current BCD (positive common)

A label next to the connector identifies the type of board.

The 25-pin female connector provides the following BCD signals representing the weight value as it is displayed on the terminal, i.e. the number of divisions multiplied by the value of the division.



The operating limits for this output type are as follows:

$$V_{\text{out Max}} = +24\text{V}$$

$$I_{\text{out Max}} = + 10 \text{ mA}$$

---

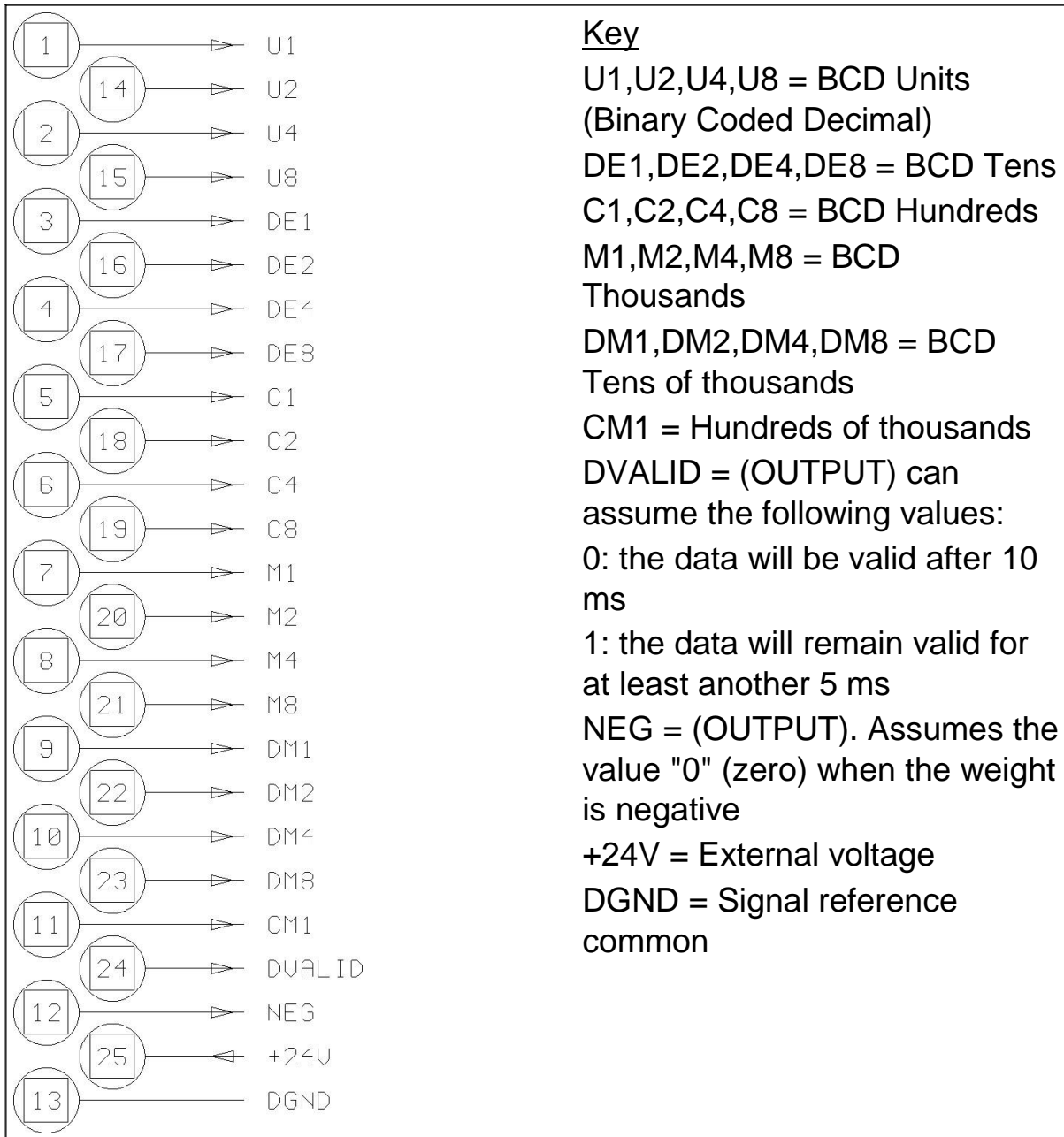

Figure 8.6 - Parallel 24V source current BCD output connector (log0062.gif)

The diagram below shows an example of a BCD 24V source current connection between the terminal and an external device.

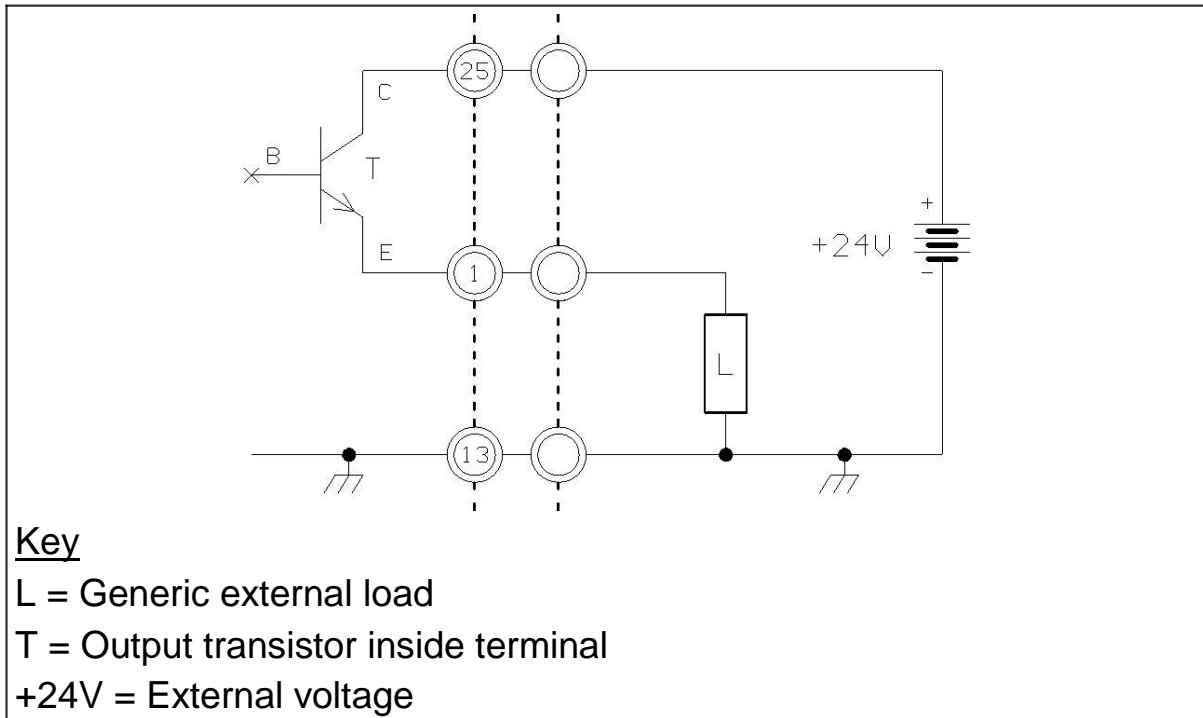

Figure 8.7 - Example of 24V source current connection (log0063.gif)

## 8.6 Serial port expansion board

The board provides 2 connectors:

- ✓ 9-pin female D-type connector (one RS232/422/485 serial port)(comx1);
- ✓ 8-pin RJ45 connector (one RS232/422/485 serial port)(comx2).

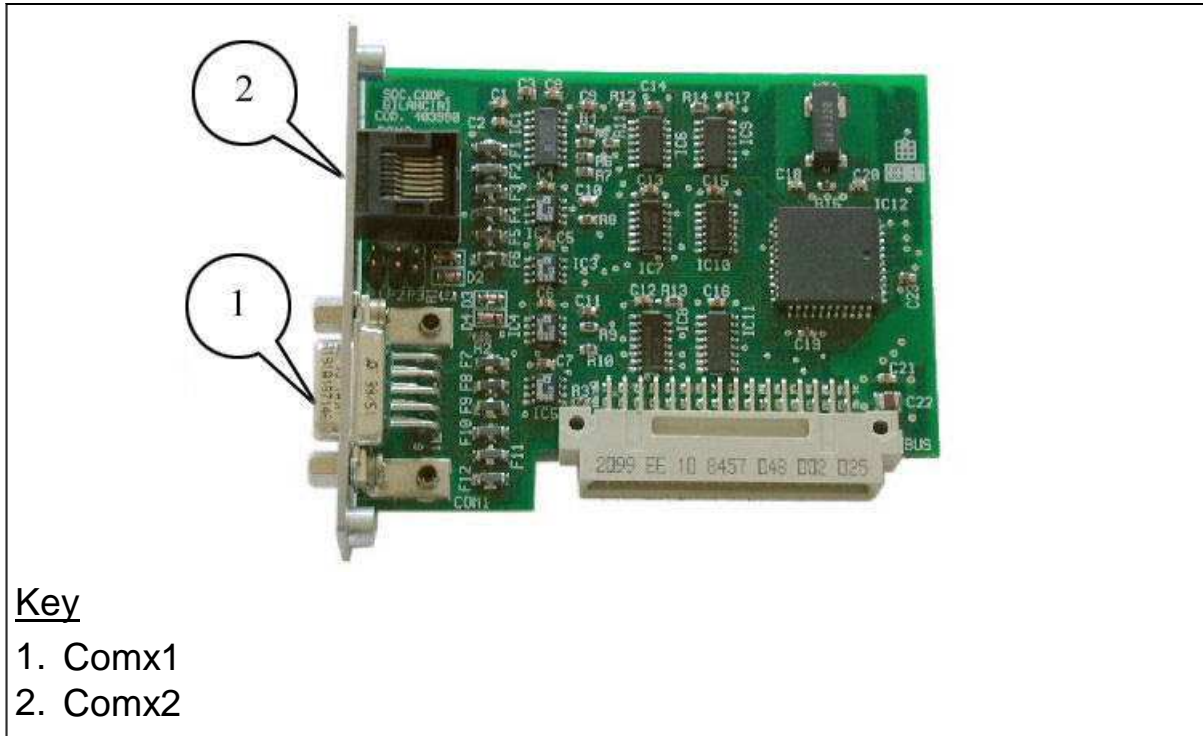

Figure 8.8 - Serial port designation (log0129.jpg)

The operating limits stipulated by the RS232/422/485 standards are indicated in par. 3.3 on page 1-27 and in par. 3.4 on page 1-28 .

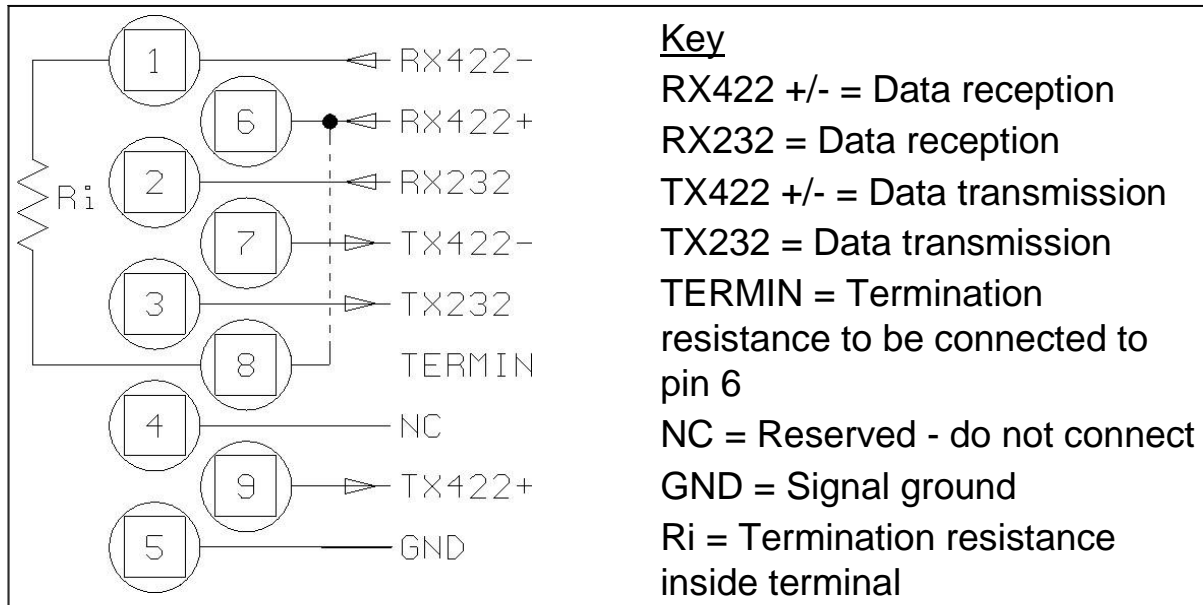

Figure 8.9 -Supplementary serial port connector (9-pin female D-type) (log0064.gif)

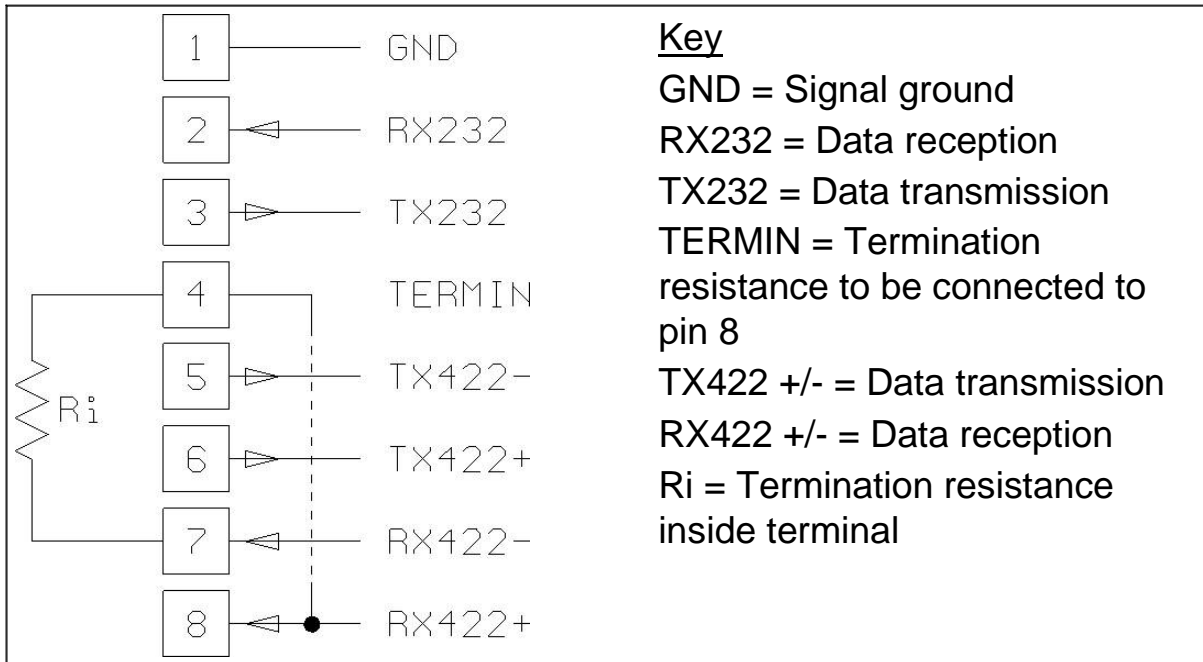

Figure 8.10 - Supplementray serial port connector (RJ45 8-pin)(comx2) (log0065.gif)

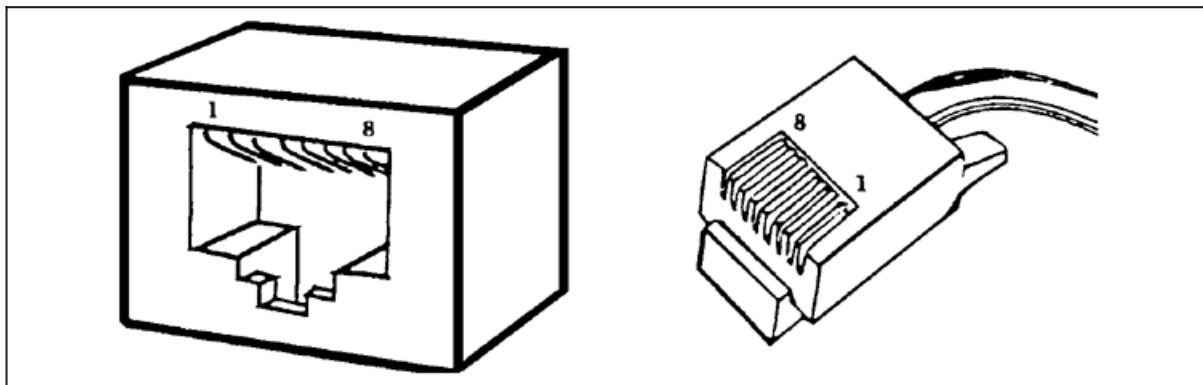

Figure 8.11 - Pin numbering for RJ-45 8-pin connector (log0066.gif)

### 8.6.1 Jumper RS485 - COMx2

- P1 = ON      PIN 5 - PIN 7 (RJ45 - COMx2)
- P2 = ON      PIN 4 - PIN 8 (RJ45 - COMx2)
- P3 = ON      PIN 6 - PIN 8 (RJ45 - COMx2)

## 8.7 MPP memory expansion boards

Terminals equipped with the MPP option (Permanent Weight Memory) can save the weight data of each single weighing operation in a permanent memory or print a paper record (type-approved printer) and transmit the values to a peripheral device, along with an identification code that is automatically assigned by the terminal.

In the case of printing the data (on a type-approved printer), it is not necessary to install the internal optional board. By entering the identification code on the terminal or by checking the paper records, it is possible to verify that the data are correct. The identification number comprises 7 digits, which means that the number will be repeated after 10.000.000 weighing operations.

### 8.7.1 Memory capacity

The memory capacity of the MPP expansion board is sufficient to store the data for approximately 130,000 weighing operations (weight + tare), which corresponds to around 8 months of continuous use of the terminal, performing 500 weighing operations per day.

If the terminal is used less frequently, this period will be extended.



---

When maximum memory capacity is reached, the oldest data are deleted and replaced by the most recent.

---

### 8.7.2 Operation

The type of MPP operation is defined during installation.

There are two main types of operating mode (for further details see the advanced user manual):

- ✓ in the first type, the user operates from the terminal by pressing  to save and transfer the weight data;
- ✓ in the second type, the user works from the PC keyboard in the way determined by the specific software.

In both operating modes, on completion of the saving operation, the user can display the progressive number associated with the weighing operation (see par. 8.7.4 on page 1-118 ).

Code MPP will only appear on the display when the memorising operation is enabled with the key.

Both the weighing terminal and the PC may signal errors caused by failure to transfer or save the data correctly. In this event, follow the on-screen instructions.

### 8.7.3 Disabling MPP

It may sometimes occur that you do not wish to transfer the weight data or save it in the MPP memory.

In this case, to disable MPP, type:

```
2°F>MPP>DE-ACTIVATED>SELECT>ESC>ESC
```

To subsequently re-enable MPP operation:

```
2°F>MPP>WITH MEMORY>SELECT>ESC>ESC
```



### **WARNING**

Disabling MPP may compromise the operation of equipment connected to the weighing system in that data transfer to such equipment will be inhibited.

---

#### 8.7.4 Checking memorised weight data

Proceed with the following operations to check the memorized weight data:

2°F>MPPCOD

The terminal displays the net weight and the tare associated with the MPP identification code of the last weighing operation to be performed. By pressing `SETCOD` you can call up previous weighing operation data by entering the relative code number.

If the terminal is equipped with a printer, by pressing  you can print the weight data displayed and the relative identification code.

The MPP terminal number or serial number may appear in the print heading, depending on the type of response selected during the installation phase.

### 8.8 12-24Vac-dc input power supplier

The terminal can be powered with a very low safety voltage rating. Ask for installation of the power supplier box with 12-24Vac-dc input. Use the supplied 2-pin connector to connect to the power source. Use a cable with two 1-2mm<sup>2</sup> section conductors.

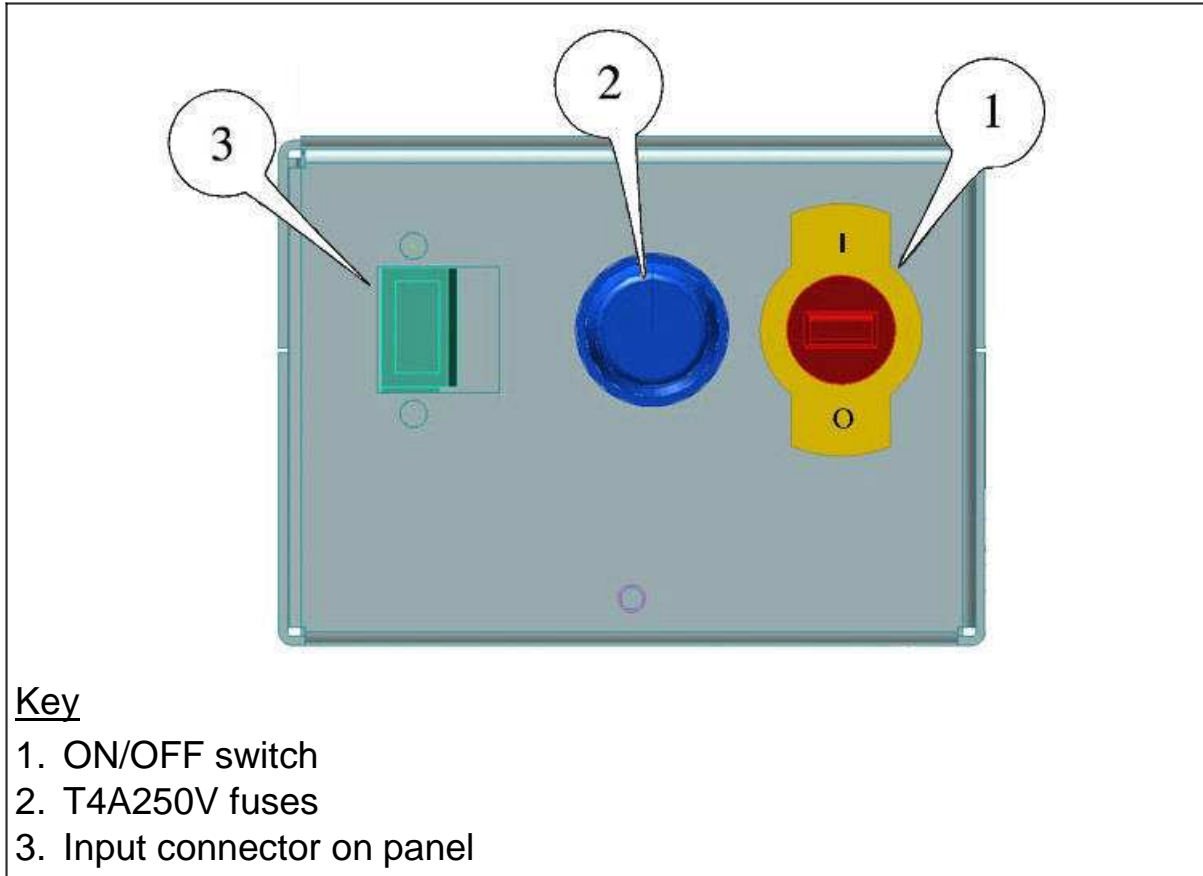

Figure 8.12 Connection to the power source with very low safety voltage rating (citi0201.jpg)

 CAUTION 

---

Peak use conditions:

DC (direct current):  $V_{min}=11V_{dc}$   $V_{max}=28V_{dc}$

AC (alternate current):  $V_{min}=12V_{ac}$   $V_{max}=24V_{ac}$

Maximum power draw=50W

Power cable (not supplied): 2 conductors with 1-2mm<sup>2</sup> section

---

## 8.9 Printers

The printer is usually connected to the terminal by way of the COM1 serial port ( Figure 8.13 on page 1-121 ), although in some exceptional cases it may be connected to the COM2 port.

Refer to the job order documentation if particular connections are required.

Refer to the printer instruction manual for the printing specifications, instructions about how to change the paper, inked tape, servicing, fuse replacement, etc.

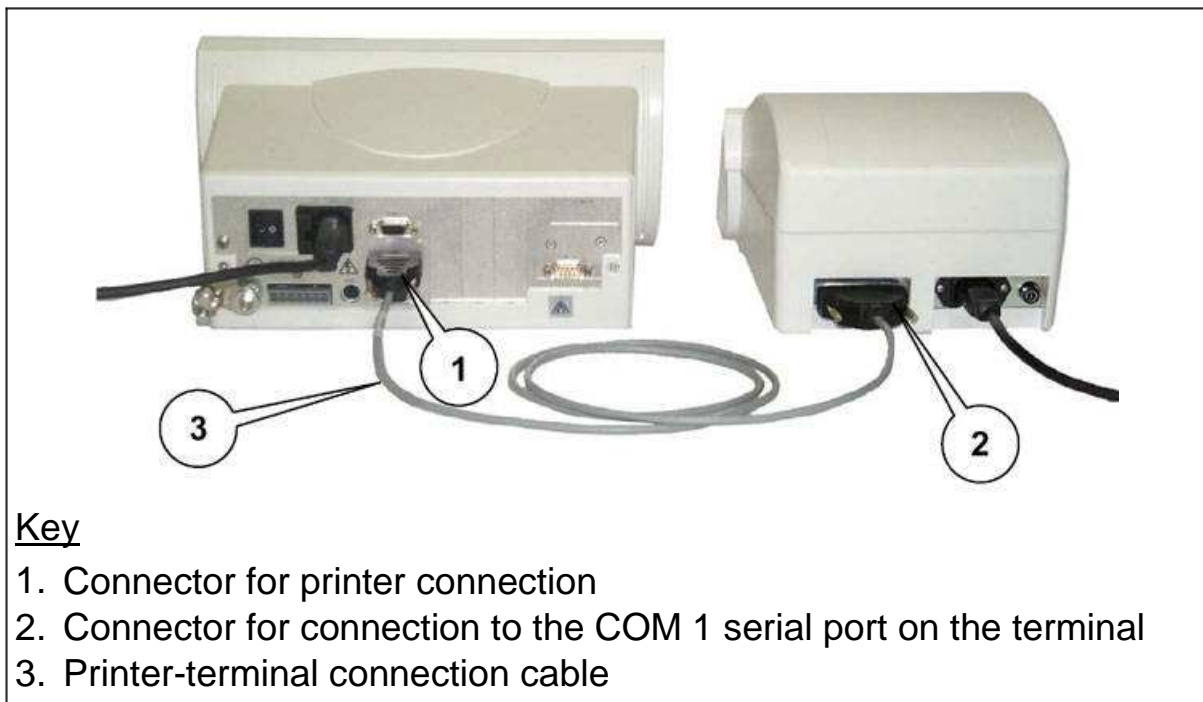

### Key

1. Connector for printer connection
2. Connector for connection to the COM 1 serial port on the terminal
3. Printer-terminal connection cable

Figure 8.13 Example of printer connection to COM1 (citi0411.jpg)

## 8.10 Connection of terminals in a network

Several weighing terminals can be connected in a network so that weighing operations can be carried out from different stations and the data shared.

For example, in the case of double weighing operations you can make the first weight on one terminal and the second weight on a different terminal, recalling the data memorized for the first weight.

The network also allows code archives, preset and total weight archives to be shared.

The network requires a configuration made during the installation phase. In order to operate, one of the terminals in the network must be configured as a server. This must always remain powered and connected. Failing this, the individual terminals will be able to work in local mode but will not be able to share the data.

Totals management has an additional option in network mode. When the general totals are recalled or by code, you can decide if the total in question concerns weighing operations carried out by a single terminal or if you wish to obtain the total of all the operations carried out by the terminals linked to the network.

Choose the type of total as indicated in par. 5.4.30 on page 1-77 .

Press either `NET` or `LOCAL` to choose where to extract the total you require.

If you decide to reset, remember that this operation will become effective for the previously selected destination.

## 9. MAINTENANCE

### 9.1 Battery

On switching on the terminal, it performs a check on the condition of the internal lithium battery. If the battery is discharged, the terminal displays the message `CHANGE THE BATTERY`. To change the battery, contact the Assistance Service.

### 9.2 Changing the fuses

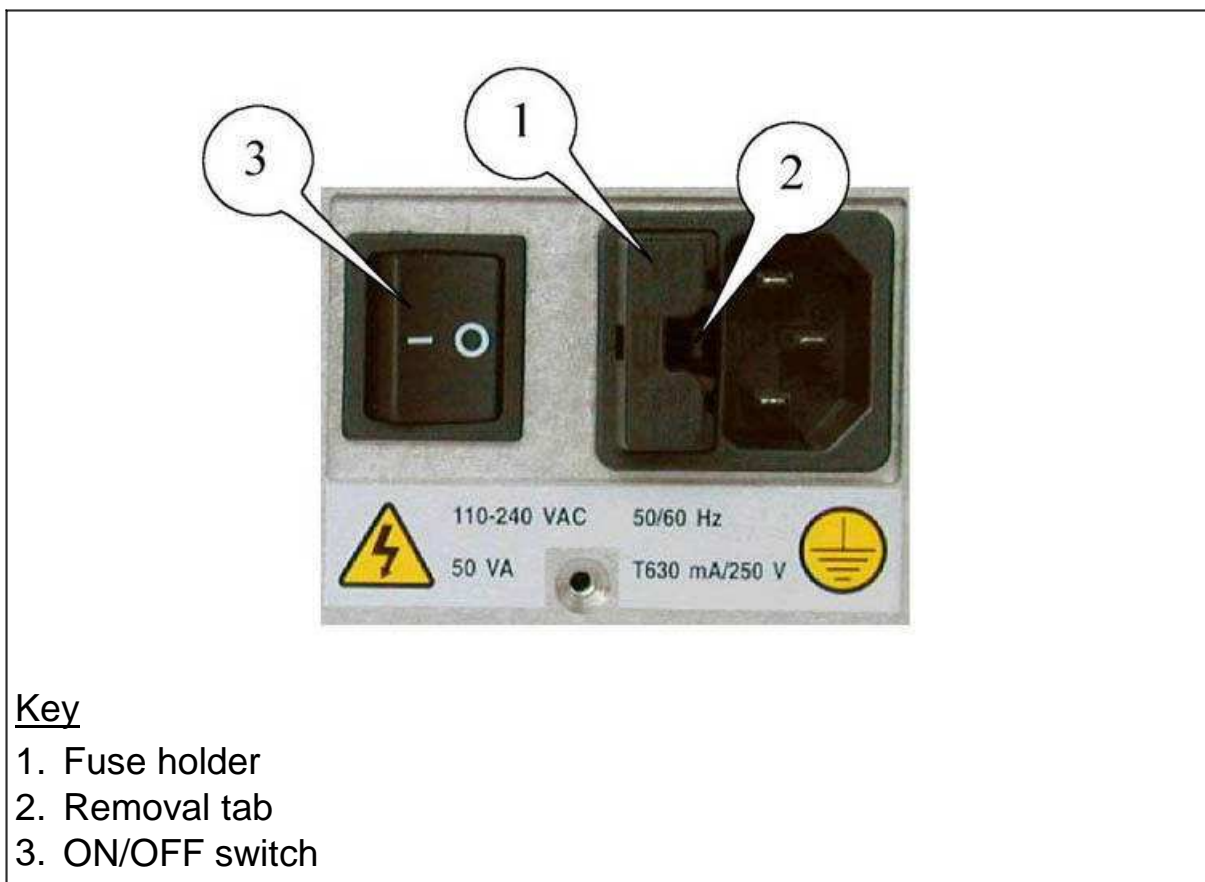

Figure 9.1 - Fuse (log0126.jpg)

**! DANGER !**



Disconnect the INPUT/OUTPUT cables and the mains lead.

- ✓ Refer to Figure 9.1 on page 1-123
- ✓ Turn the ON/OFF switch to O (off).
- ✓ Press the tab and withdraw the fuse holder.
- ✓ Replace blown fuses with new ones of the same rating (T630mA250V time delay).
- ✓ If the fuse blows again on switching on the terminal, do not make any further attempts to replace it but contact Assistance Service.

## 10. TROUBLESHOOTING

If the suggested remedy does not solve the problem, contact Assistance Service.

### 10.1 Malfunctions

Problem	Cause	Remedy
The terminal does not switch on	No power	<p>Check that power arrives at the mains outlet socket.</p> <p>Check that the mains lead is correctly plugged in.</p> <p>Check that the ON/OFF switch is in the position I (ON).</p> <p>Check the fuses.</p>
The display backlighting is on, but no data are displayed	Adjust contrast (set to minimum)	<p>Switch on the terminal while holding pressed .</p> <p>After a few seconds, the display will show the "CB" logo with the contrast set to maximum, after which the contrast will gradually be reduced.</p> <p>Release  and then press it again to set the contrast at the required level.</p>
- -	Zeroing off-range on powering	Switch off the terminal, unload the scale then power the terminal again.

## 10.2 Error messages

Problem	Cause	Remedy
9999999 flashing	The scale is overloaded.	Reduce the weight to a value below the maximum scale capacity.
-01-	Converter fault.	Contact Assistance Service.
	Scale connector disconnected or broken.	Switch off the terminal and check that the connector is properly connected. If necessary, disconnect and then re-connect the connector. Switch the terminal back on.
	Digital cells fail to respond	Switch the terminal off and then on again.
-02-	EEPROM error	Switch the terminal off and then on again.
-04-	RAM checksum error	Switch the terminal off and then on again.
-05-	PROGRAM checksum error	Switch the terminal off and then on again.
-06-	Serial number error on digital cell	Switch the terminal off and then on again.

-07-	Digital cell serial number error in system with several load cells	Switch the terminal off and then on again.
-08-	Digital cell serial number error	Switch the terminal off and then on again.
-09-	Digital cell serial number and configuration error	Switch the terminal off and then on again.
-10-	At least one cell not configured	Switch the terminal off and then on again.
-11-	Digital cell powering error	Switch the terminal off and then on again.
-12-	Powering error in one digital cell	Switch the terminal off and then on again.
-13-	Cell with internal temperature off-limits (-40 - 100) °C	Switch the terminal off and then on again.

Change the battery	Internal lithium battery discharged	Contact Assistance Service
Weight not valid	The scale is in negative weight or overload condition and the printer does not print	See conditions for correct printing in par. 5.5 on page 1-82
Printer error	Printer switched off or disconnected	Check printer is connected and switched on
The last line at the bottom of the display of the terminal may show an error message in the following format:  excep n.nn in task xx.x  where n.nn and xx.x are numbers or letters that encode the type of error.	Depends on n.nn and xx.x	Switch the terminal off and then on again.  If the error persists, contact the Assistance Service and give them the exact message that appears on the display.

The `Diagnostics` item of the user menu will allow you to establish the cause of errors concerning the digital cells. Consult par. 5.4.13 on page 1-70.



---

.

---